

Flush-mount microphones

- For aeroacoustic measurements

NEW



Aerospace



Automotive



Rail transportation

G.R.A.S.
SOUND & VIBRATION

Flush-mount microphones

This new 47xx family of acoustic sensors combines the high precision and reliability of G.R.A.S. measurement microphones with the need for fitting sensors into very confined spaces and narrow structures. With an installation height of less than 10 mm, thin coax wiring and front venting, the flush-mount series can be integrated into literally any design and application.

- *High precision 1/2", 1/4" & 1/8" measurement microphones*
- *Very low installation height – smallest footprint available*
- *Integrated preamplifier with plug & measure functionality*
- *Wide flat frequency range*
- *Wide dynamic range*
- *Unique diaphragm repair service*

NEW

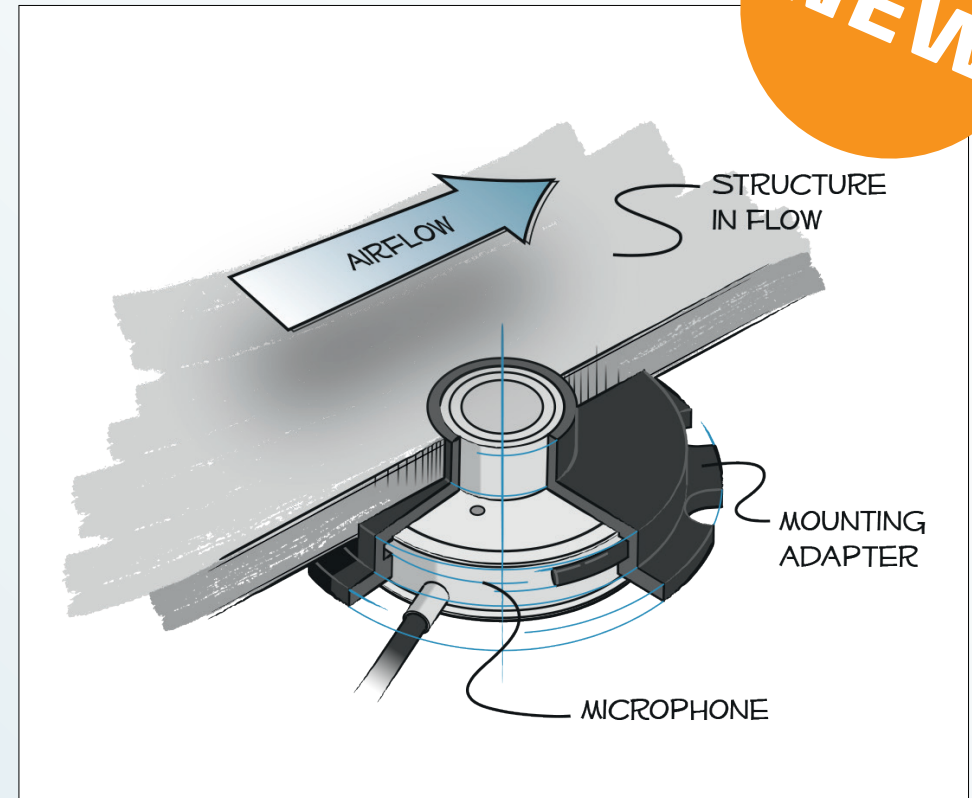

Flush-mount Family

G.R.A.S. 47AX,
47BX, 47DX

Frequency range	3.15 Hz - 100 kHz
Dynamic range	22 dB(A) - 178 dB
Sensitivity	0.9 - 12.5 mV/Pa
Venting	Front

We Make Microphones

As the only 100% focused developer and manufacturer of measurement microphones, our goal is to provide our customers with the right sensor for the right application. Whether this is realized through a standard, special or customized sensor solution, our concern and priority are always to help our customers

achieve the best possible measurement results – every time.

All our microphones are based on our founder Gunnar Rasmussen's innovative and world-famous measurement microphone design. Designs that have set the

reference for all measurement microphones for more than 50 years. This evolution enables us to offer 5 years microphone warranty and the unique diaphragm repair service. Find more information and your local G.R.A.S. partner at gras.dk

LI0140 0614