

Instruction Manual

42AE Low-frequency Calibrator



Revision History

Any feedback or questions about this document are welcome at gras@gras.dk.

Revision	Date	Description
1	7 September 2011	First publication
2	19 July 2012	Revision. New introduction to measurement setups. Information about how to handle heat build-up in the coupler.

Copyright Notice

© 2011–2012 G.R.A.S. Sound & Vibration A/S

<http://www.gras.dk>

Any technical documentation that is made available by G.R.A.S. is the copyrighted work of G.R.A.S. and is owned by G.R.A.S.

The content in this document is subject to change without notice. G.R.A.S. Sound & Vibration A/S is not liable or responsible for any errors or inaccuracies that may appear in this document.

Trademarks

Product names mentioned in this document may be trademarks or registered trademarks of their respective companies and are hereby acknowledged.

Contents

Introduction.....	4
Principles of Operation.....	4
Delivered Items.....	6
External Features and Connections.....	8
Calibrator Head and Coupler	8
Calibration Configurations and Measurement Setups	9
Introduction	9
Single Channel Measurement.....	10
Dual-channel Measurements.....	12
Mechanical Assembly.....	14
Handling and Pressure Equalisation.....	14
Single-channel Configuration	14
Dual-channel Configuration	14
Mechanical Assembly – 1" Microphone	15
Mechanical Assembly – ½" Microphone	16
Mechanical Assembly – ¼" Microphone	17
Mechanical Assembly – ⅛" microphone.....	18
Ordering Information.....	19
Specifications	20
Calibration.....	21
Warranty.....	21
Service and Repairs.....	21

Introduction

Principles of Operation

The GRAS 42AE Low Frequency Calibrator is designed to calibrate microphones to below 0.1 Hz. The 42AE comes with a two port calibration head and a comprehensive range of accessories for mounting of all standard microphone sizes.

A measurement microphone measures the difference in pressure between the front of a diaphragm and the pressure on the back of the diaphragm. Therefore, the front side should not be exposed to the pressure on the back side in the frequency range one is interested in measuring. At very low pressure alterations – like weather changes – it is important to equalize the front pressure with the back pressure to avoid static deformation of the diaphragm. The time it takes to equalize the pressure difference determines the low frequency performance of the microphone. In a sound field, the wavelength of the impinging sound also plays an important role. International standard IEC 61094-2 does not take this into consideration.

The 42AE has been developed to enable calibration at frequencies below 100 Hz where the precision of other methods like reciprocity and electrostatic actuator start to degrade. The low frequency calibrator is based on a well defined force acting on a large piston that constitutes the wall of a small volume. Acoustic pressure is defined as a varying excess pressure in a medium. It is measured as force per unit area, Newton per square meter (N/m²).

In the calibrator, the force (F) is delivered by a current (I) in a coil of the length (L) placed in a homogeneous magnetic field, (B): $F = B \times I \times L$.

The current (I) may be monitored as the voltage drop across a built-in resistor to obtain a calibration value in mV/Pa.

The piston diameter is 55 mm. It is suspended in a very soft gas-tight diaphragm and acts on a very small volume. The excursion of the piston is very small: 0.4 μ per mm³.

42AE will automatically compensate for the ratio of 1.4 for specific heats adiabatic to isothermal which is of importance for low frequency calibration and not taken into account by other methods.

Front-vented microphones equalize the pressure inside the microphone through an opening placed much less than 1/4 wavelength from the front of the diaphragm.

Back-vented microphones shall be used with attention to the place where the equalization takes place, i.e. a small hole in the preamplifier housing.

Front-vented microphones may be preferred for infrasound measurements or the preamplifier should be provided with a small hole in the housing.

The G.R.A.S 1" microphone 40EN offers the possibility to adjust the equalization as needed as well as choosing front or back venting.

Calculation of the Low-Frequency Cut-off

In addition to the acoustically determined low-frequency cut-off, the input impedance of the preamplifier and the capacity of the microphone cartridge introduce an electric influence on the low-frequency response of a given microphone. The obtainable cut-off frequency will thus vary according to the actual combination of preamplifier and microphone. In Fig. 1 the typical resulting low-frequency cut-off from various microphone and preamplifier combinations are shown.

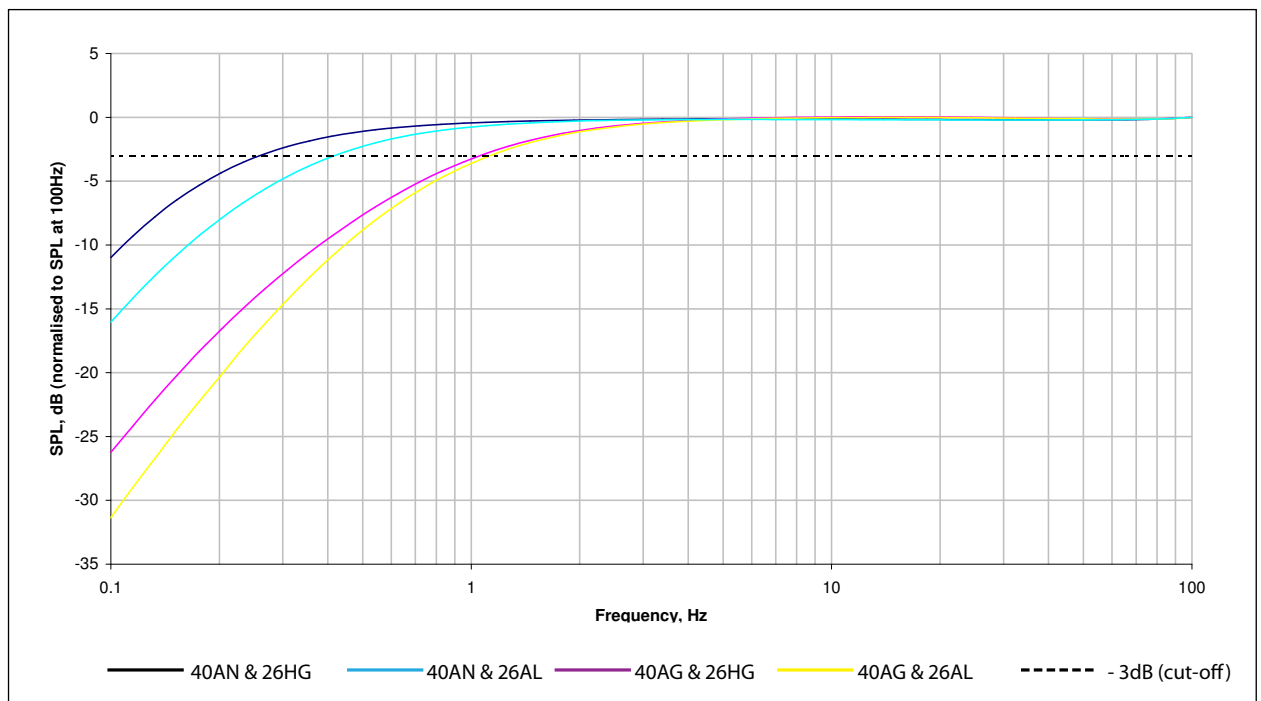

Fig. 1. Typical frequency ranges depending upon various combinations of microphones (40AG and 40AN) and preamplifiers (26AL and 26HG). The dotted line is at -3 dB.

The figure clearly shows that the lowest cut-off can be obtained combining the 40AN $\frac{1}{2}$ " Microphone, Low Frequency and the 26HG $\frac{1}{4}$ " Preamplifier, Low Frequency.

Calculation of the cut-off frequency

When the preamplifier input impedance and the capacity of the microphone are known, the actual cut-off-frequency for a specific calibration set-up can be calculated according to this equation:

$$f_L = \frac{1}{2\pi \cdot C \cdot Z_I}$$

f_L = Low-Frequency 3-dB Limit [Hz]
 C = Capacity of Microphone Cartridge [F]
 Z_I = Preamplifier Input Impedance [Ω]

Refer to the calibration charts for the specific microphones and preamplifiers for the exact data needed for this calculation.

Delivered Items

Check that you have received all the items shown in the following tables and figures.

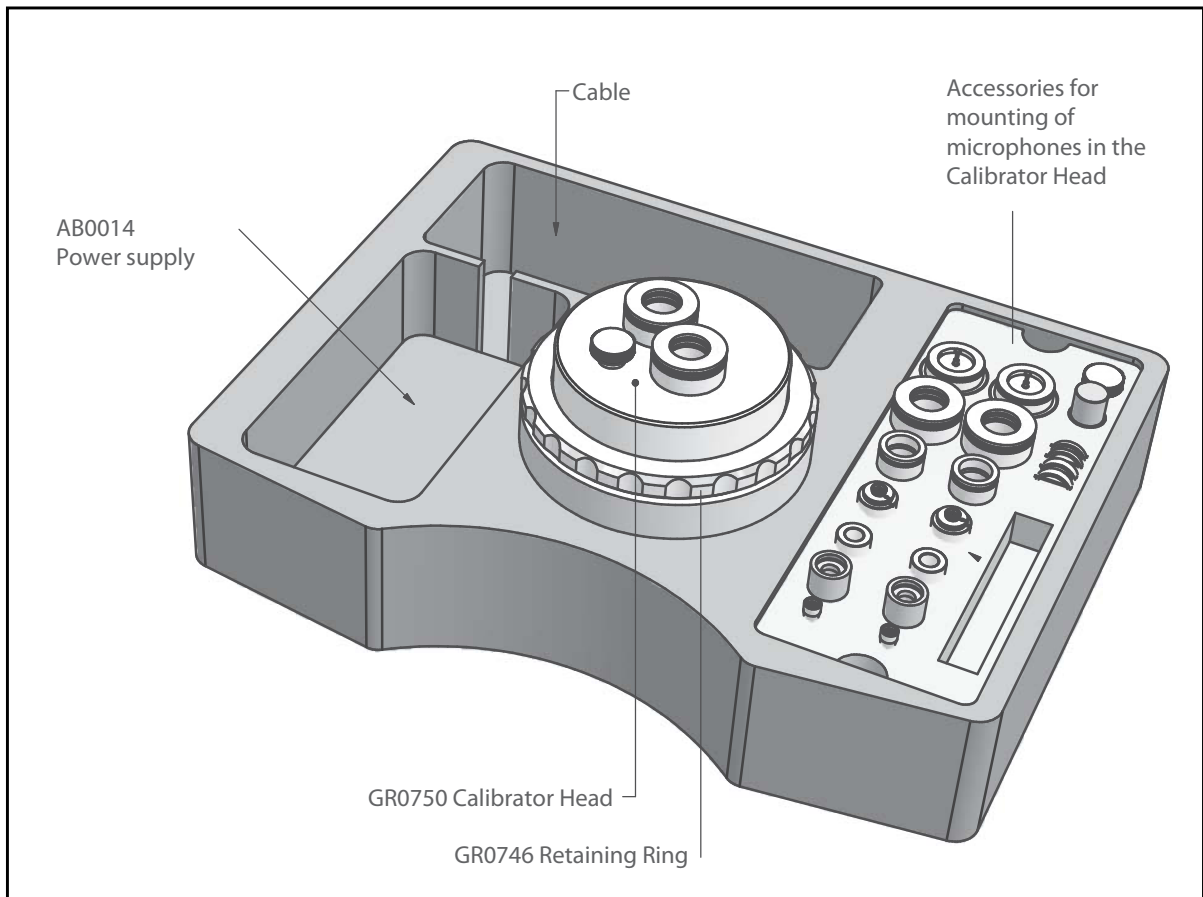

Fig. 2. The 42AE Low-Frequency Calibrator and accessories for sealed mounting of 1" to 1/8" microphones.

Items included

Power Supply (not shown)	AB0014
Power cable (not shown)	
Calibrator Head	GR0750
Retaining Ring	GR0746

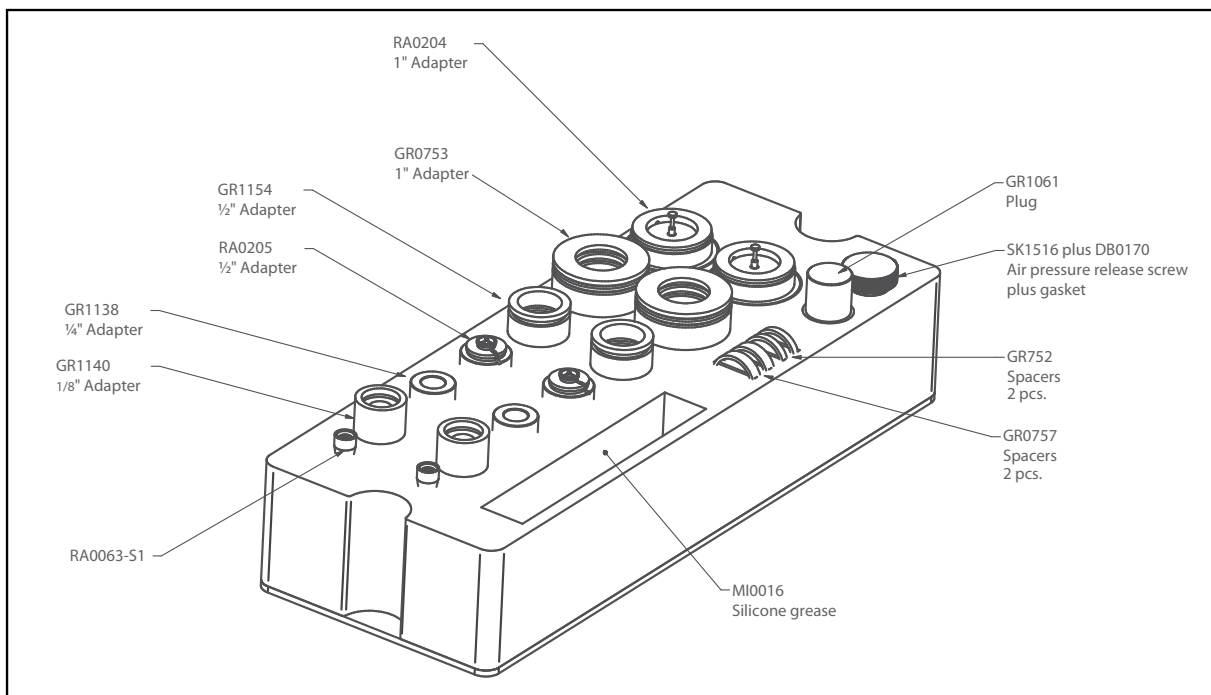

Fig. 3. Accessories for sealed mounting of 1" to 1/8" microphones.

2 x Adapter for 1" microphones	RA0204
2 x Adapter housing	GR0753
2 x Adapters for 1/2" preamplifiers	GR1154
2 x Adapters for 1/2" preamplifiers	RA0205
2 x Adapters for 1/4" microphones	GR1138
2 x Adapters for 1/8" microphones	GR1140
2 x Adapters for 1/8" to 1/4" microphones	RA0063-S1
Silicone grease	MI0016
2 x 3.7 mm spacers	GR0757
2 x 2.2 mm spacers	GR0752
Pressure release items	SK1516 + DB0170
Plug	GR1061

Optional Accessories

Optional accessories and reference microphones are listed on page 19.

External Features and Connections

Calibrator Head and Coupler

The Calibrator Head (GR0750) included with the 42AE is for both single and dual-channel measurements using 1", ½", ¼", and ⅛" microphones. The calibrator head is attached to the body by the Retaining Ring GR0746. In combination with an O-ring, the retaining ring ensures an airtight seal. The microphones under test are flush-mounted in the calibrator head, pointing down towards the piston.



Fig. 4. The Calibrator Head removed to expose top of piston, the Calibrator Head, and flush-mounted microphones.

External Features and Electrical Connections

The external features used to assemble and hook up the 42AE are shown in Fig. 5: The calibrator head, retaining ring, and calibrator housing with input and output sockets as well as a green LED. See "Calibration Configurations and Measurement Setups" and "Mechanical Assembly" for in detail descriptions of the separate setups and configurations, including how different sizes of microphones are mounted.

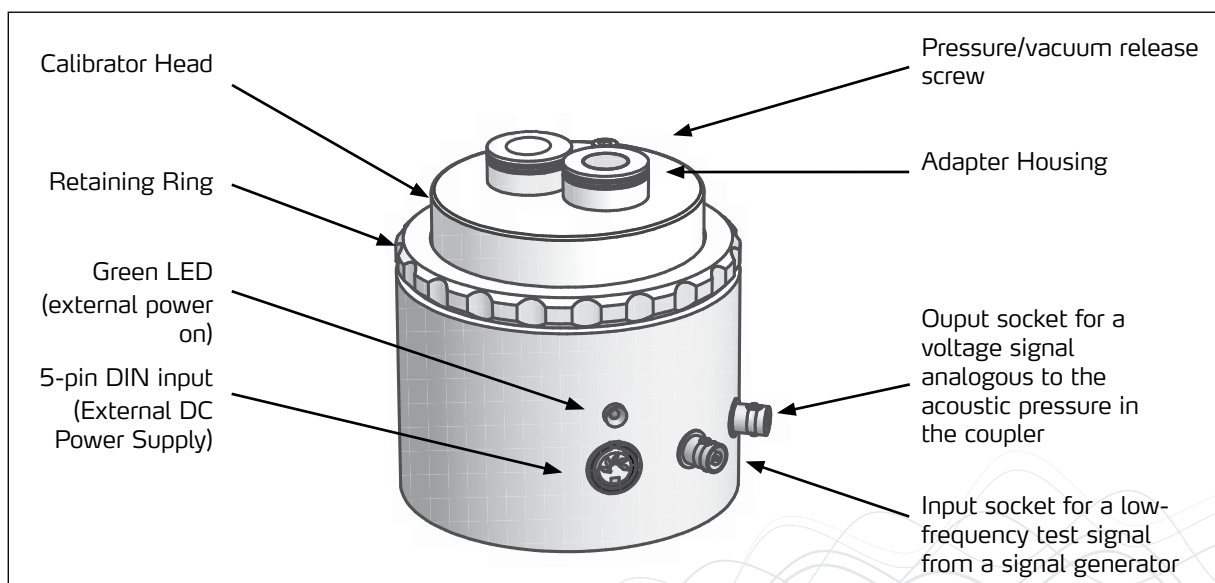

Fig. 5. External features of the body.

Calibration Configurations and Measurement Setups

Introduction

By design, the 42AE establishes a precise relationship between the force applied to the piston and the acoustical output generated by the piston. To achieve reliable and reproducible measurements, the following must be taken into account:

- The 42AE is a low-frequency calibrator dedicated to examining the low-frequency characteristics of microphones, in particular quantifying their corner frequencies due to acoustic venting.

While absolute calibrations of single microphones are possible, we recommend that the microphone under test be calibrated against a reference microphone.

- The pressure in the chamber is delivered by a speaker. The 'Calibration' output measures the current across the speaker's coil and is factory-calibrated against a known pressure level of 137dB re. 20 μ Pa.

Under the assumption that the speaker parameters remain constant with time, a direct relationship exists between the current across the coil and the consequent pressure delivered. This relationship is indirectly the stated sensitivity (in mV/Pa) of the 42AE.

- The measurement chamber is small and air-tight and is therefore sensitive to changes in ambient conditions.

Continuous testing with the 42AE will cause a temperature rise due to heating of the speaker coil and electrical components. This in turn will cause a drift in measurements.

Therefore, it is recommended to separate tests by 30 minutes to allow the chamber to return to the initial conditions.

Important: It is crucial that the pressure in the chamber is equalized between measurements; this is done using the pressure release valve.

- When performing swept sine measurements, we recommend sweeping from low to high frequencies due to initial transient effects exhibited by the piston. At low frequencies, these will have negligible effects.
- The recommended operational frequency range is 100 mHz – 100 Hz.

Single Channel Measurement

The 42AE can be configured for single or dual-channel calibrations and measurements. In single-channel configurations, the Device Under Test (DUT) is a microphone cartridge with a given preamplifier.

The low-frequency response of the DUT is measured against the known Sound Pressure Level in the coupler of the 42AE (SPL_{coupler}), nominally 5 mV/Pa.

The acoustic pressure in the coupler can be derived via the voltage signal available via the BNC output socket described in Fig. 6. This voltage signal is directly proportional to the acoustic pressure in the coupler, nominally 5 mV/Pa. The exact figure is given in the individual calibration chart provided with the 42AE.

Basic Requirements

- 42AE
- Device Under Test (DUT), including preamplifier
- AB0014 Power Supply
- 12AR 2-Channel Power Module
- A computer/analyzer that is capable of:
 - Generating low-frequency signals
 - Signal analysis
 - Processing and presenting all required measurement results in terms of SPL_{DUT} vs. SPL_{coupler} , phase data, etc.

Calibration of a single microphone – SPL_{DUT} compared to $SPL_{COUPLER}$

Fig. 6 shows a typical measurement setup for a single-channel configuration. The low frequency response of a microphone is compared to the reference signal from the coupler.

- The low-frequency response of a microphone, (SPL_{DUT}) is measured against the known Sound Pressure Level ($SPL_{coupler}$) in the coupler of the 42AE.
- The analog voltage signal from the 42AE is directly proportional to the acoustic pressure in the coupler (5 mV/Pa. – see calibration chart for exact value).
- The 12AR 2-Channel Power Module is recommended because it can be used at frequencies down to 0.05 Hz.

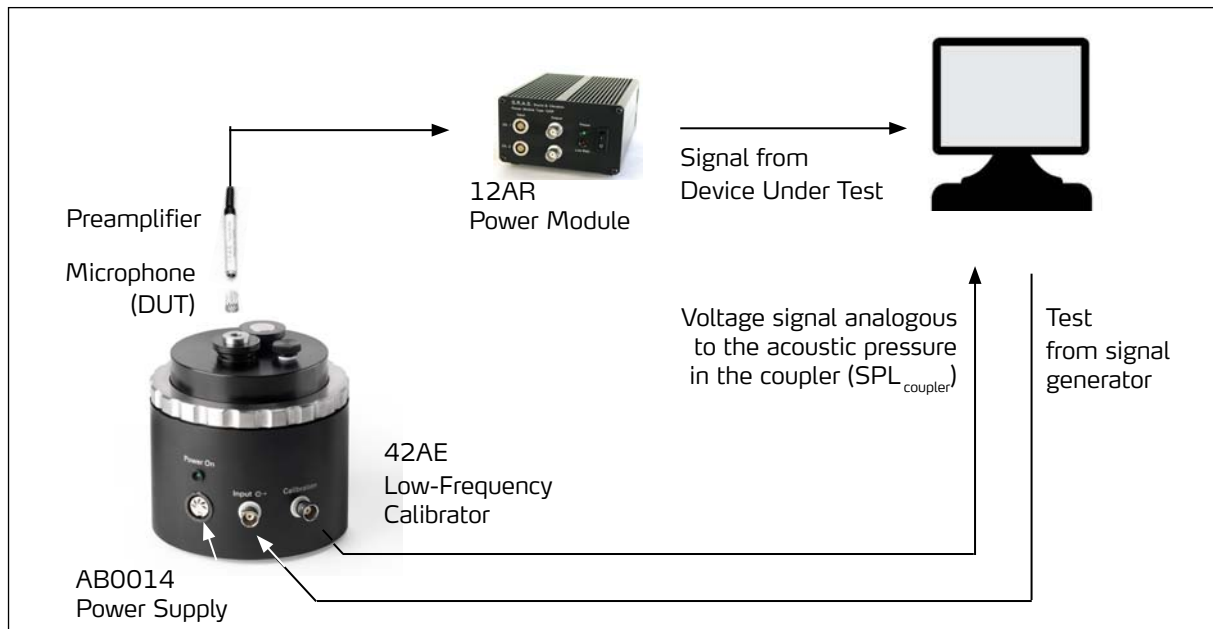

Fig. 6. Typical single-channel measurement set-up.

Dual-channel Measurements

When configured for dual-channel measurements, the DUT is measured against another microphone with known properties, the reference device (ref. dev.). A dual setup does not necessarily have to be symmetrical.

The 42AE is delivered with a comprehensive set of accessories that makes it possible to mount any combination of 1", ½", ¼", and ⅛" microphones, where the DUT is mounted in one port and the reference device in the other. Fig. 7 shows a typical measurement setup for a dual-channel configuration.

LF response Compared with a Reference Device

The low-frequency response of a microphone is measured against the Sound Pressure Level ($SPL_{ref\ dev}$) of a reference device.

- The 12AR 2-Channel Power Module is recommended because it can be used at frequencies down to 0.05 Hz.
- The computer/analyzer must be capable of generating low-frequency signals.
- The software in the computer/analyzer must be capable of processing and presenting all required measurement results in terms of:

SPL_{DUT} vs. $SPL_{ref\ dev}$

where SPL_{DUT} is the Sound Pressure Level as measured by the Device Under Test – i.e. the microphone under test.

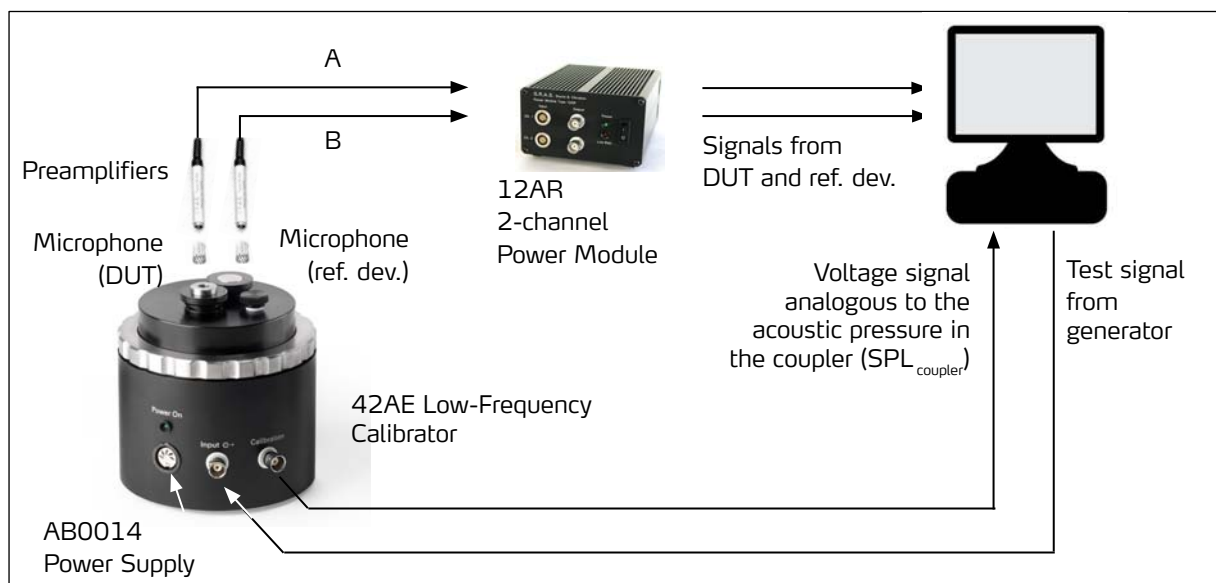

Fig. 7. Measurement set up for dual-channel measurement.

Matching a Pair of Microphones – Phase and Pressure Response

Fig. 8 shows a measurement setup that can be used for symmetrical dual-channel configurations. The setup is for comparing the low-frequency phase and pressure response of a pair of matched microphones (A and B) to each other.

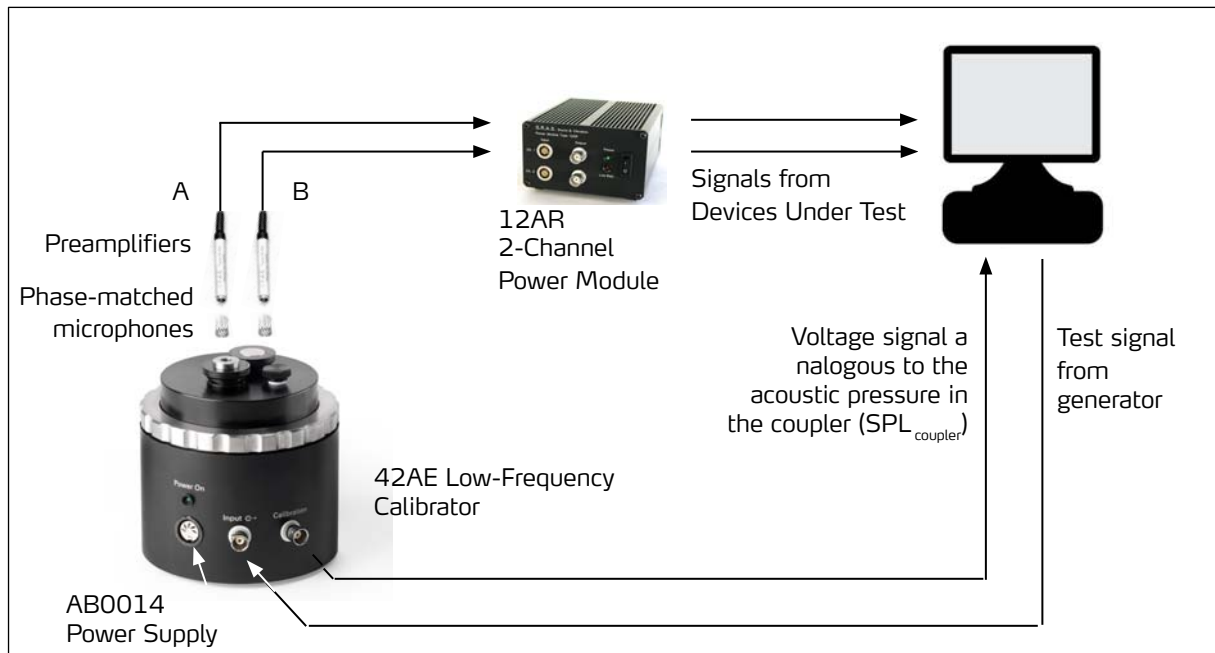

Fig. 8. Measurement set up for dual-channel measurement.

To check the similarity of a pair of phase-matched microphones, the measurement setup must be symmetrical as shown in Fig. 8.

- The voltage signal from the 42AE is analogous to the acoustic pressure and phase angle within the coupler of the 42AE.
- The relationship between acoustic pressure and voltage output is nominally 5 mV/Pa. (see calibration chart for exact value).
- The 12AR 2-Channel Power Module is recommended because it can be used at frequencies down to 0.05 Hz.
- The software in the computer/analyzer must be capable of generating low-frequency signals.
- The software in the computer/analyzer must be capable of processing and presenting all required measurement results in terms of:

$$\text{SPL}/\varnothing_{A \text{ or } B} \text{ vs. } \text{SPL}/\varnothing_{\text{coup}} \text{ and/or}$$

$$\text{SPL}/\varnothing_A \text{ vs. } \text{SPL}/\varnothing_B,$$

where A and B refer to the two microphones under test, SPL is the Sound Pressure Level and \varnothing is the phase angle.

Mechanical Assembly

Handling and Pressure Equalisation

As described in the Introduction, the 42AE has an air-tight measurement chamber. All physical user-serviceable components are manufactured to very close tolerances to ensure tight fits. Use only finger pressure because all fits are push fits. To secure air-tight fits, apply a tiny amount of silicone grease before fitting the items.

Important: Variations in atmospheric pressure can cause an overpressure or vacuum in the coupler. To prevent this, the pressure relief screw (SK1516 + DB0170) provided on the calibrator head must remain slackened when the 42 AE is not in use and during assembly. Tighten it before making a measurement.

Important: Continuous use of the 42AE will cause the temperature inside the measurement chamber to rise. Therefore, it is recommended to separate tests by 30 minutes to allow the chamber to return to the initial conditions. It is crucial that the pressure in the chamber is equalized between measurements, using the pressure release valve.

Single-channel Configuration

When used for single-channel measurements, the microphone is mounted in one port and the other port is sealed off. In this case, the microphone is measured against the analogous voltage signal generated by the 42AE. This signal is directly proportional to the sound pressure inside the coupler. The low-frequency response is measured against the known Sound Pressure Level (SPL_{coupler}) within the coupler of the 42AE.

Dual-channel Configuration

For dual-channel measurements, microphones are fitted into both ports, and the microphone is measured against a known reference or against the voltage signal representing the known pressure inside the coupler. A dual setup does not necessarily have to be symmetrical. Any combination of $\frac{1}{2}$ ", $\frac{1}{4}$ ", and $\frac{1}{8}$ " microphones can be used. Refer to the following pages for the items needed for mounting of the different sizes of microphones.

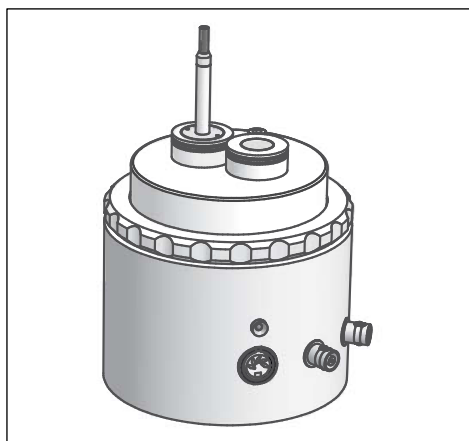

Fig. 9. Example of completed assembly for single-channel measurements.

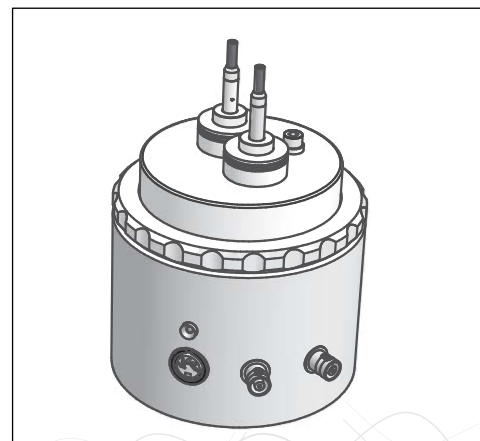

Fig. 10. Example of completed assembly for dual-channel measurements.

Mechanical Assembly – 1" Microphone

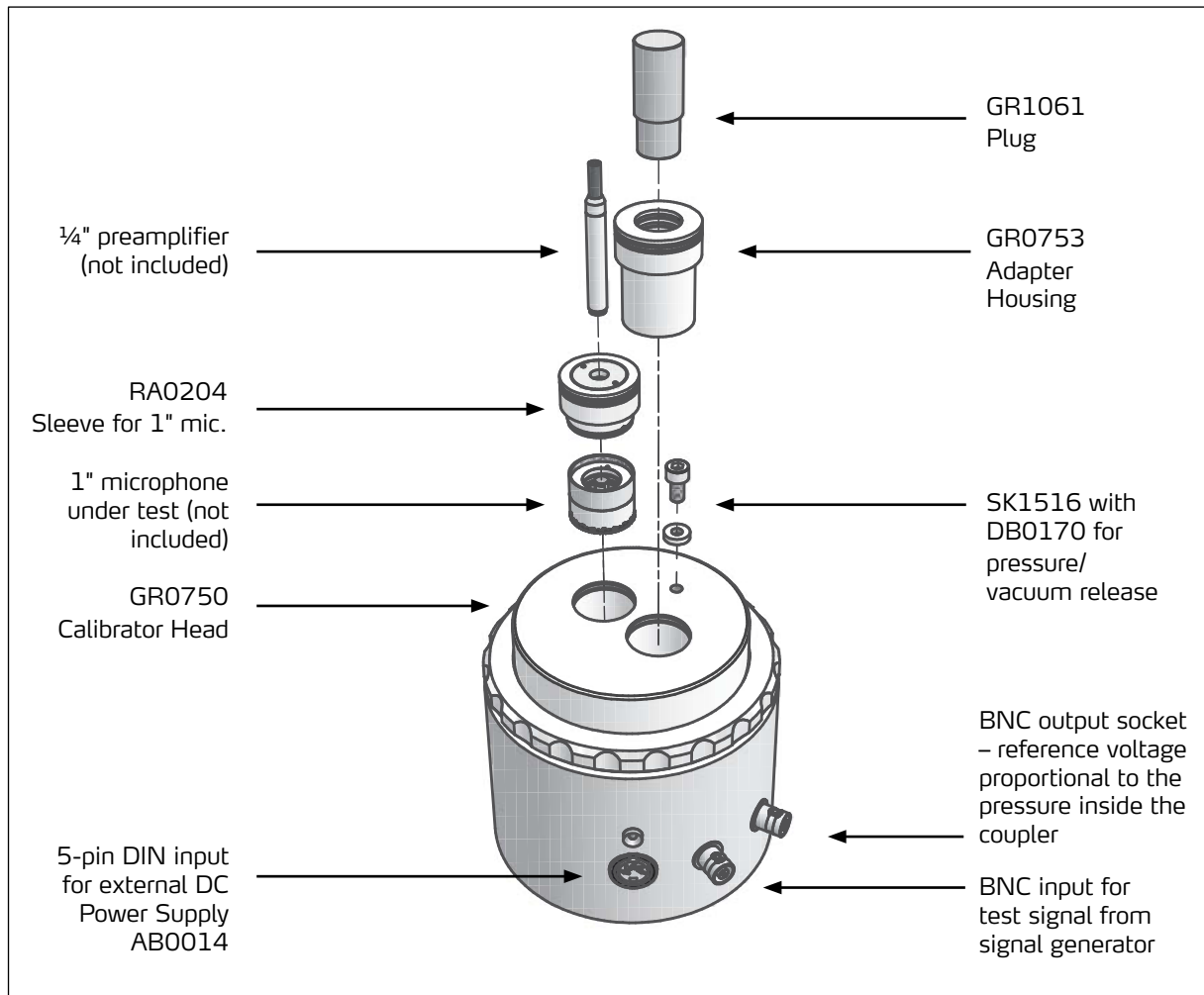

Fig. 11. The 42AE configured for calibrating a 1" microphone.

Single-channel Configuration

The calibrator head is designed for calibrating two microphones. For single-channel measurements, the microphone is mounted into one port of the calibration head (here the one to the left) and the other port is sealed.

Fig. 11 shows the items needed for a measurement setup for calibrating a single 1" microphone.

Dual-channel Configuration

When configured for dual-channel measurements, both ports are used, and the procedures for mounting two similarly sized microphones are identical. For assembly instructions for 1/2", 1/4" and 1/8" microphones, see page 16, page 17, and page 18, respectively.

Mechanical Assembly – ½" Microphone

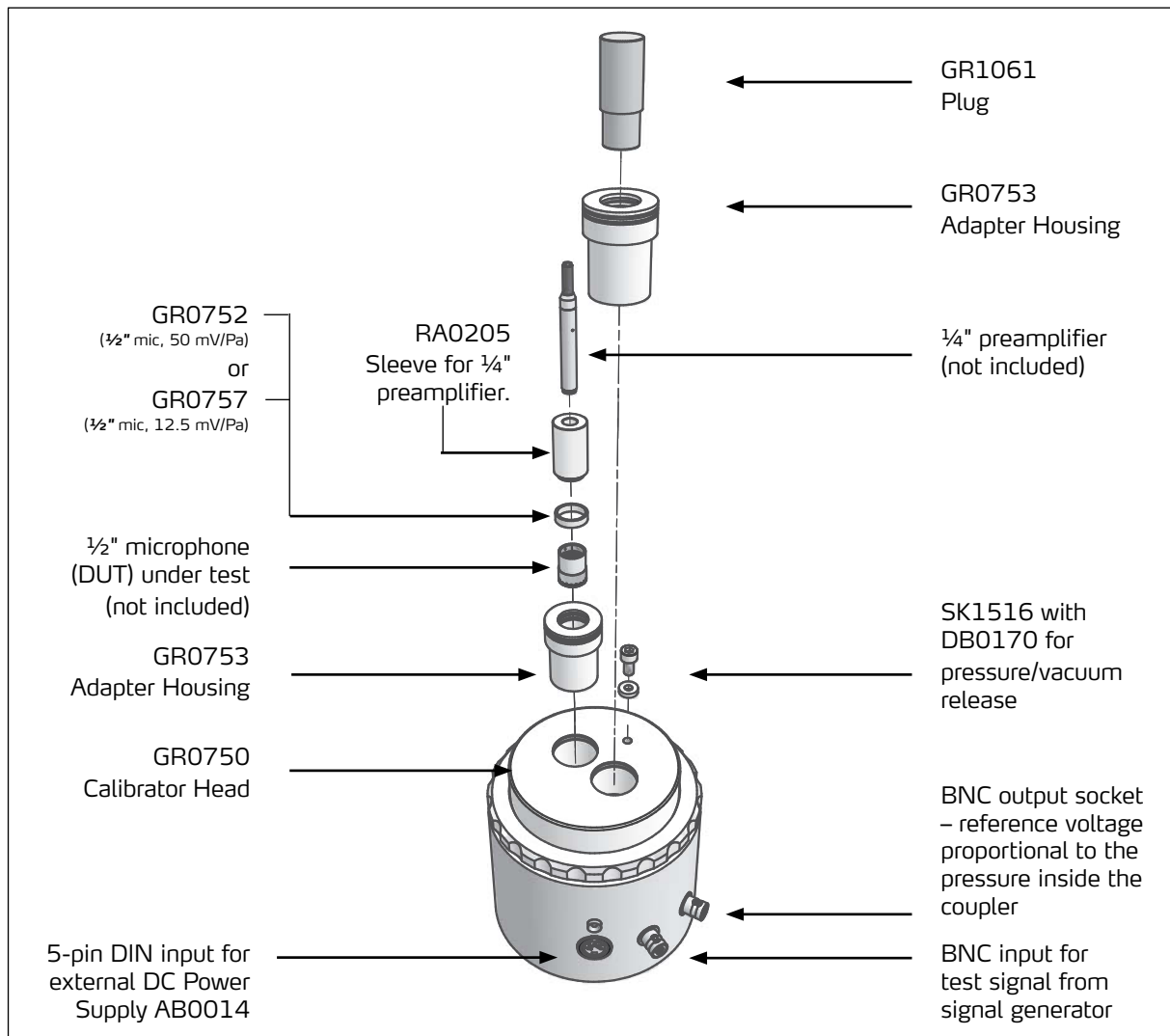

Fig. 12. 42AE configured for calibrating a ½" microphone in a single-channel set-up.

Single-channel Configuration

The coupler head is designed for mounting two microphones. For single-channel measurements, the microphone is mounted into one port of the calibration head (here the one to the left) and the other port is sealed. Fig. 12 shows the items needed for calibrating a single ½" microphone.

Dual-channel Configuration

When configured for dual-channel measurements, both ports are used, and the procedure for mounting two similarly sized microphones is identical. For assembly instructions for 1", ¼", and ⅛" microphones, see page 15, page 17, and page 18 respectively. The calibrator can be used for both rear-vented and front-vented microphones mounted with GRAS preamplifiers. In the case of microphone sets from other manufacturers, an adapter (GR1154, see page 7) is included to determine if the venting through another manufacturer's preamplifier is sufficient.

Mechanical Assembly – ¼" Microphone

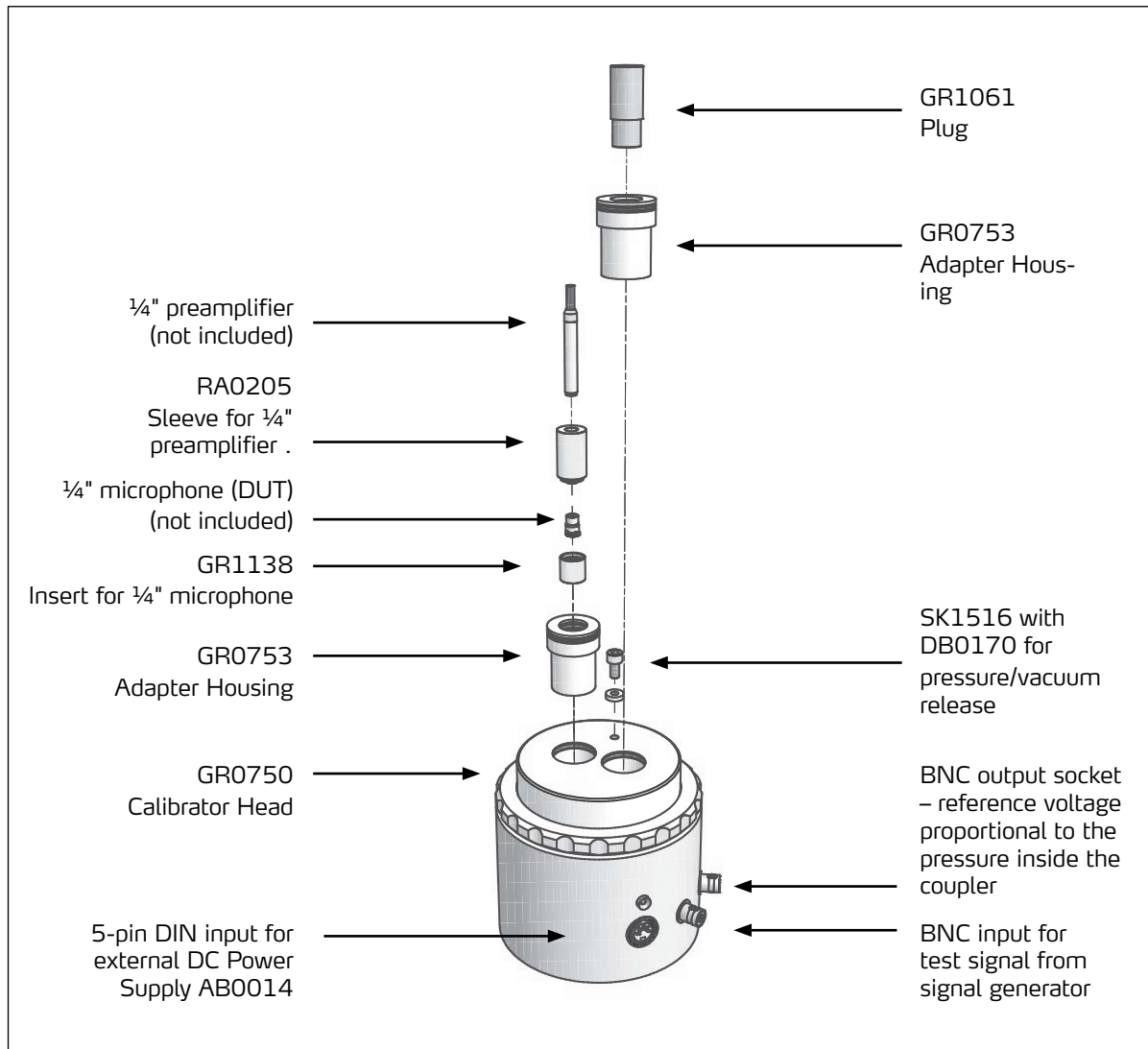

Fig. 13. 42AE configured for calibrating a ¼" microphone.

Single-channel Configuration

The calibrator head is designed for mounting two microphones. For single-channel measurements, the microphone is mounted into one port of the calibration head (here the one to the left) and the other port is sealed.

Fig. 13 shows the items needed for a measurement setup for calibrating a single ¼" microphone.

Dual-channel Configuration

When configured for dual-channel measurements, both ports are used, and the procedure for mounting two similarly sized microphones is identical. For assembly instructions for 1", ½", and ⅜" microphones, see page 15, page 16, and page 18 respectively.

Mechanical Assembly – 1/8" microphone

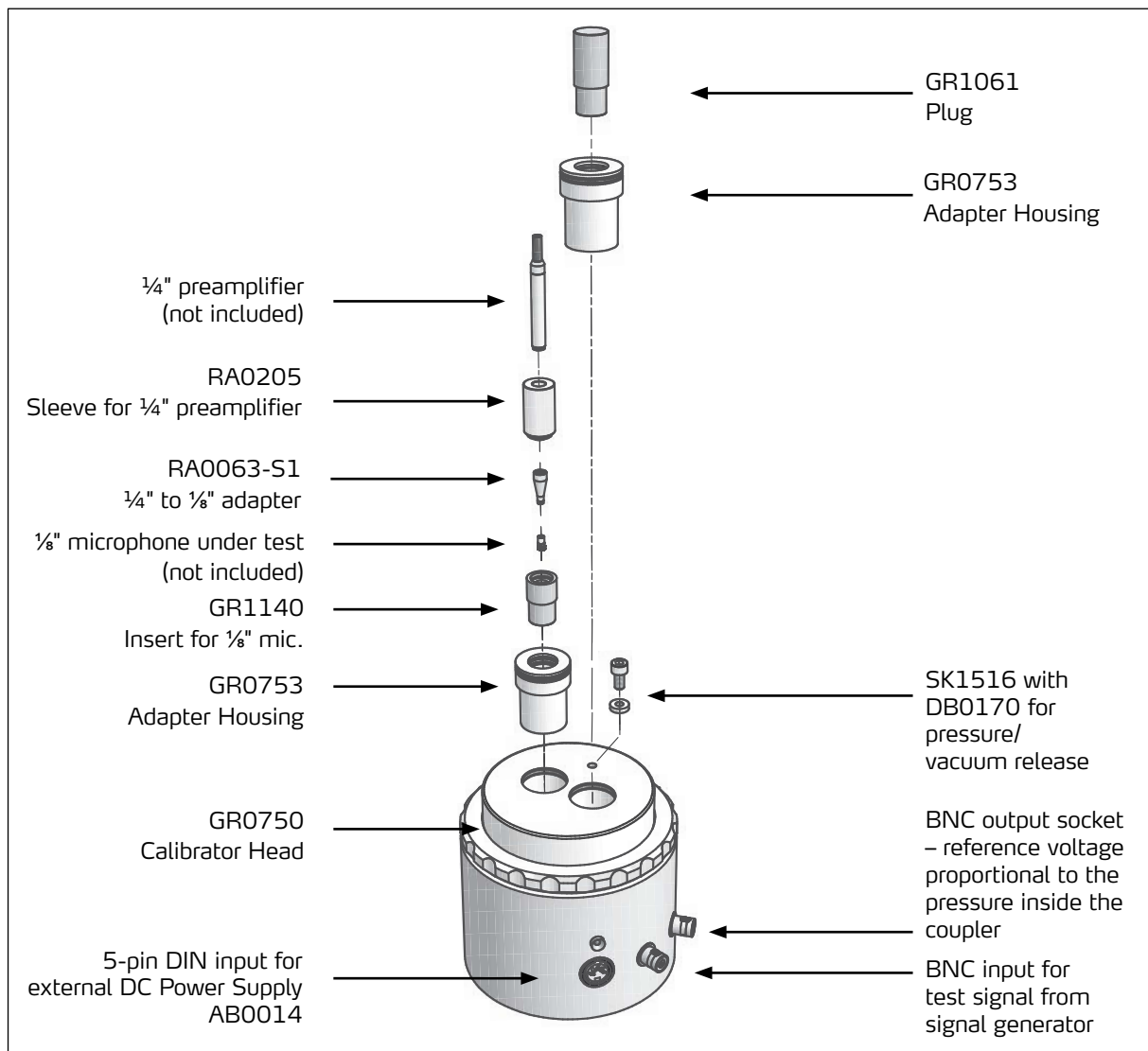

Fig. 14. 42AE configured for calibrating a 1/8" microphone.

Single-channel Configuration

The coupler head is designed for mounting two microphones. For single-channel measurements, the microphone is mounted into one port of the calibration head (here the one to the left) and the other port is sealed. Fig. 14 shows the items needed for a measurement setup for calibrating a single 1/8" microphone.

Dual-channel Configuration

When configured for dual-channel measurements, both ports are used, and the procedure for mounting two similarly sized microphones are identical. For assembly instructions for 1", 1/2", and 1/4" microphones, see page 15, page 16, and page 17 respectively.

Ordering Information

Included Items	Part Number
Calibrator Head	GR0750
Retaining Ring	GR0746
2 x Adapter for 1" microphones	RA0204
2 x Adapter housing	GR0753
2 x Adapters for ½" preamplifiers	GR1154
2 x Adapters for ½" preamplifiers	RA0205
2x Adapters for ¼" microphones	GR1138
2 x Adapters for ⅛" microphones	GR1140
2x Adapters for ⅛" to ¼" microphones	RA0063-S1
Silicone grease	MI0016
2x3.7mm spacers	GR0757
2x2.2mm spacers	GR0752
Pressure release items	SK1516 + DB0170
Plug	GR1061

Accessories available

Dual-channel Power module	12AR
Reference microphones	
Externally polarized	
½" Microphone	40AN
¼" Preamplifier	26HG
Prepolarized	
½" Microphone	40AZ
¼" Preamplifier	26CG

Specifications

Calibration level

Max. level	140 dB (re 20 μ Pa)
------------	-------------------------

Frequency range from below 0.1 Hz to above 100 Hz: max. 500 Hz using comparison technique (2 microphones). Recommended frequency range is 0.1 Hz – 100Hz.

Accuracy – calibration of a microphone against a reference microphone

Amplitude

100 mHz – 100 Hz	± 0.5 dB
500 mHz – 100 Hz	± 0.1 dB
1 Hz- 100 Hz	± 0.05 dB

Phase

100 mHz – 100 Hz	$\pm 3^\circ$
500 mHz – 100 Hz	$\pm 0.5^\circ$
1 Hz- 100 Hz	$\pm 0.1^\circ$

Accuracy – absolute calibration of a single microphone alone

Amplitude

100 mHz – 100 Hz	± 1 dB
500 mHz – 100 Hz	± 0.5 dB
1 Hz- 100 Hz	± 0.2 dB

Phase

100 mHz – 100 Hz	$\pm 5^\circ$
500 mHz – 100 Hz	$\pm 3^\circ$
1 Hz- 100 Hz	$\pm 1^\circ$

Signal input

Socket	BNC
Max. input level	± 0.707 V RMS
Impedance	1 M Ω

Signal output – analogous to acoustic pressure in coupler

Socket	BNC
Output level	5mV/Pa, (140dB (re. 20 μ Pa))
Impedance	1 Ω

Power – provided by included external DC power supply AB0014

Socket	5-pin DIN
Voltage supply	± 15 V
Current	1 A max.

Dimensions and weight

Height	117.95 mm (4.64")
Diameter	114.0 mm (4.49")
Weight	1.58 kg (3½ lbs)

Calibration

Before leaving the factory, all G.R.A.S. products are calibrated in a controlled laboratory environment using traceable calibration equipment.

We recommend a yearly recalibration at minimum, depending on the use, measurement environment, and internal quality control programs.

Warranty

All G.R.A.S. products are made of high-quality materials that will ensure life-long stability and robustness. The 42AE is delivered with a 2-year warranty.

Damaged diaphragms in microphones can be replaced.

The warranty does not cover products that are damaged due to negligent use, an incorrect power supply, or an incorrect connection to the equipment.

Service and Repairs

All repairs are made at G.R.A.S. International Support Center located in Denmark. Our Support Center is equipped with the newest test equipment and staffed with dedicated and highly skilled engineers. Upon request, we make cost estimates based on fixed repair categories. If a product covered by warranty is sent for service, it is repaired free of charge, unless the damage is the result of negligent use or other violations of the warranty. All repairs are delivered with a service report, as well as an updated calibration chart.

G.R.A.S. Sound & Vibration continually strives to improve the quality of our products for our customers; therefore, the specifications and accessories are subject to change.

Manufactured to conform with:

CE marking directive:
93/68/EEC



WEEE directive:
2002/96/EC



RoHS directive:
2002/95/EC



G.R.A.S. Sound & Vibration continually strives to improve the quality of our products for our customers; therefore, the specifications and accessories are subject to change.