

# ***Instruction Manual***

## *50GI-P CCP Rugged Sound Intensity Probe*



## Revision History

Any feedback or questions about this document are welcome at [gras@gras.dk](mailto:gras@gras.dk).

Revision	Date	Description
1	5 November 2013	First publication
2	5 June 2014	New part numbers for spacers
3	28 February 2017	Page 13: PI-Index limit corrected to 29 dB

## Copyright Notice

© 2014-17 G.R.A.S. Sound & Vibration A/S

[www.gras.dk](http://www.gras.dk)

## Trademarks

Product names mentioned in this document may be trademarks or registered trademarks of their respective companies and are hereby acknowledged.

## Contents

<b>Introduction and Description .....</b>	<b>4</b>
Main Features .....	5
<b>Delivered Items.....</b>	<b>6</b>
<b>Assembling the Probe.....</b>	<b>7</b>
Assembling the Probe Microphones and Spacers .....	7
Changing the Spacer (to cover a different frequency range) .....	9
Adjusting the Head Angle .....	9
<b>Using the Probe .....</b>	<b>10</b>
Selecting Spacer .....	10
Sound-intensity Axis.....	10
<b>Calibration .....</b>	<b>11</b>
Preparing for Calibration.....	11
Checking the Sensitivity and P-I Index using a Pistonphone.....	12
Checking the Probe's P-I Index using a Sound Intensity Calibrator .....	13
<b>Ordering Information .....</b>	<b>14</b>
<b>Specifications and Warranty .....</b>	<b>15</b>
Calibration.....	15
Service and Repairs.....	15

## Introduction and Description

---

The G.R.A.S 50GI-P CCP Rugged Sound-intensity Probe is a two-microphone sound intensity probe especially designed for use in conditions calling for a rugged design. It is equipped with CCP \*transducers and a handle.

It has a G.R.A.S. 40GK-S1 phase-matched ½" microphone pair and a pair of G.R.A.S. 26CC ¼" phase-matched preamplifiers. Also, it has two right-angled adapters, three spacers, and a handle. The probe is adjustable, durable and fully meets the requirements of:

- IEC 61043, Electroacoustics – Instruments for the Measurement of Sound Intensity – Measurements with Pairs of Pressure Sensing Microphones, 1993 for Class 1 Sound-intensity probes.

The 40GK-S1 microphone pair consists of special free-field microphones with extremely well-controlled phase characteristics. It is delivered as a matched pair with individual calibration data for each microphone as well as data on the differences between their phase responses.

These microphones have a unique pressure equalization system that ensures a well defined lower-limiting frequency and an extremely low sensitivity to sound pressures at the pressure equalization channels.

## The Probe Design

### Rugged Design

The 50GI-P is a standard sound intensity probe with CCP\* microphones. However, the physical design has been optimized for use in rough environments:

- The preamplifiers are supported by stainless steel holders. The connections between preamplifiers and cables are thus protected from strain.
- The probe head is symmetrical and more rigid than an asymmetrical design.
- The robust microphone cables are attached closely to the telescopic arm, minimizing the risk for cable damage.
- The holder assembly can be securely locked at 0°, 45° and 90°, without compromising its physical stability.
- The microphones' protection grids are made of stainless steel, improving their ability to withstand rough physical treatment and protecting the microphone's diaphragms from damage.

The distance between microphones and preamplifiers has been kept to a minimum to avoid stray capacitances and sensitivity to vibration. The phase characteristics of an Intensity Probe can be critically affected by even very small vibrations. Therefore, the ¼" preamplifiers are mounted in rigid contact with the ½" microphones via short adapters. This also eliminates problems with non-matching capacitances between microphones and preamplifiers which could result in phase problems.

\*CCP = Constant Current Power

## Main Features

The 50GI-P CCP Rugged Intensity Probe is a simple-to-use and reliable probe designed with the following features:

- Complete, rugged Sound Intensity Probe for locating sound sources and for sound power measurements.
- 40GK-S1 Sound Intensity Microphone Pair with a uniquely-designed pressure equalization system that ensures extremely well defined phase characteristics.
- Two 26CC Microphone Preamplifiers housed in robust, stainless steel casings.
- Three solid spacers of various lengths and a spacer cup to cover the frequency range from 30 Hz to 10 kHz.
- A set of self-adhesive labels for identifying the microphones and preamplifiers used for channel A and B respectively.

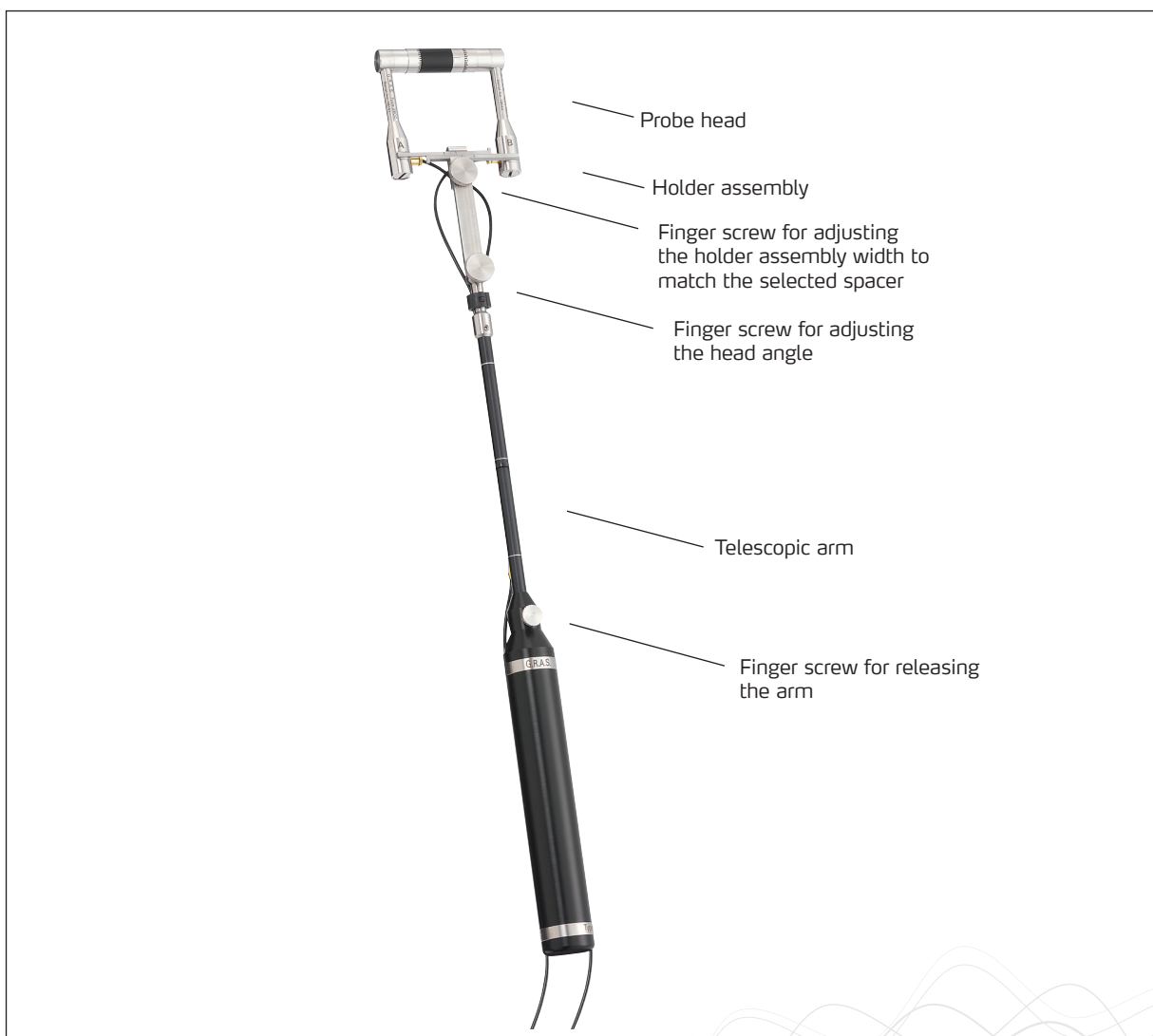

**Fig. 1.** The 50GI-P Intensity Probe.

## Delivered Items

---

The 50GI-P is delivered complete with spacers, wind screen, connection cable and extension cable. Self-adhesive labels for identifying the microphones and preamplifiers of channel A and B respectively are also included.

Item	Part number
Rugged Probe Head	RA0213
Pair of phase matched ½" microphones	40GK-S1
2 pcs Right-angled adapters	RA0001
Spacer cup	GR0040
12 mm spacer	RA0266
25 mm spacer	RA0265
50 mm spacer	RA0264
Pair of ¼" preamplifiers	26CC-Set
2 pcs SMB to Microdot cable	AA0068
2 pcs Adapter Microdot female-female	AE1038
2 pcs Microdot-BNC extension cable	AA0070
Set of self adhesive labels for channel identification (A, B)	EM0065
Handle	AI0044
Windscreen	AM0376

## Assembling the Probe

### Assembling the Probe Microphones and Spacers

The probe is assembled in a symmetrical setup, ideal for sound power measurements, for example according to the international standard ISO 9614-2 "Acoustics - Determination of sound power levels of noise sources using sound intensity" where a rotation test is required.

Fig. 2 shows an exploded view of the probe head. An assembled probe head is shown in Fig. 3.

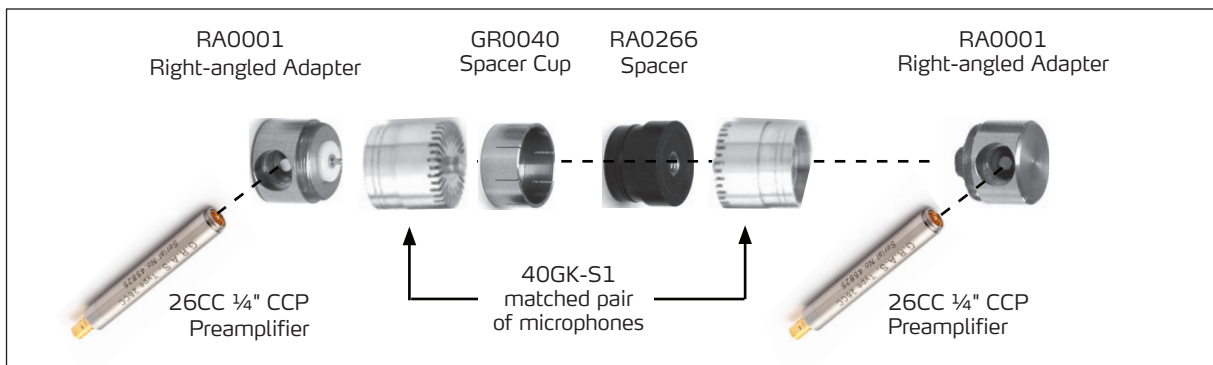

**Fig. 2.** Exploded view of probe assembly.

Assemble as follows:

1. Screw one microphone onto one RA0001 Right-angled Adapter and the other microphone onto the other Right-angled Adapter.
2. Screw the preamplifiers into the right-angled adapters.
3. Screw the GR0040 Spacer Cup onto the protection grid of one of the microphones.
4. Select the most appropriate spacer for the desired frequency range, refer to "Selecting Spacer" on page 10.
5. Screw the spacer onto the protection grid of the other microphone.
6. Assemble the two halves of the probe assembly by pushing the free end of the spacer (mounted on one of the microphones) fully into the spacer cup.

### Adjusting the Distance between the Microphone Holders

1. Loosen the finger screw at the top of the telescopic arm.
2. Adjust the distance between the two microphone holders (A and B) to match the distance between the preamplifiers. Do not tighten the finger screw at this point.

### Mounting the Microphone Assembly onto the Telescopic Arm

The microphone-preamplifiers are mounted by simultaneously pushing the preamplifiers down into the holders with your index fingers. **Important.** Take care to push evenly on the two angled adapters while supporting the holders at the same time with your thumbs.

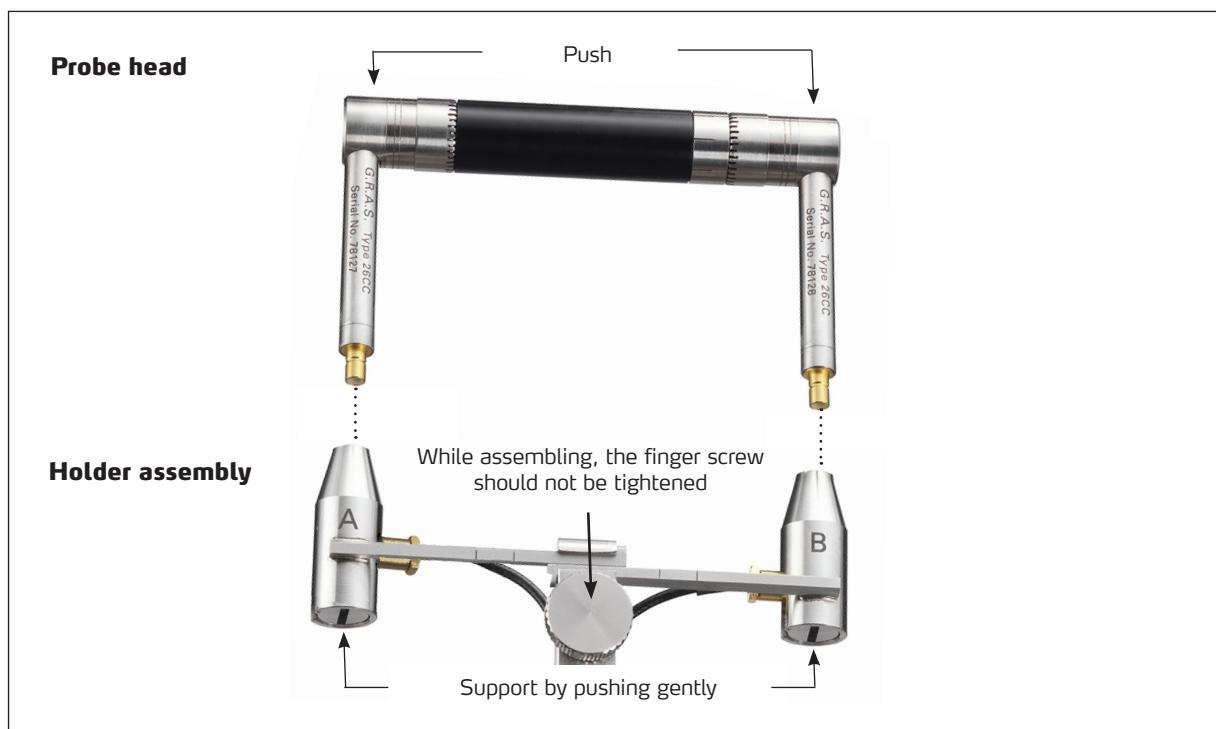

**Fig. 3.** Mounting the Probe head onto the Holder assembly.

1. Slide the preamplifiers into the holders marked A and B respectively.  
**Important.** Take care to align preamplifiers and holders to ensure that they fit smoothly.
2. Push on the right angled adapters until the preamplifiers click onto the connectors inside the holders A and B.
3. Tighten the finger screw.



### Changing the Spacer (to cover a different frequency range)

Dismantle the microphone assembly by reversing the procedure described above.

1. Pull the preamplifiers out of the holders A and B.
2. Dismantle the probe head by pulling the spacer out of the spacer cup.
3. Unscrew the spacer and replace it with the one covering the desired frequency range (See "Selecting Spacer" on page 10).

### Adjusting the Head Angle

The probe head can be locked at an angle of 0°, 45° and 90° degrees.

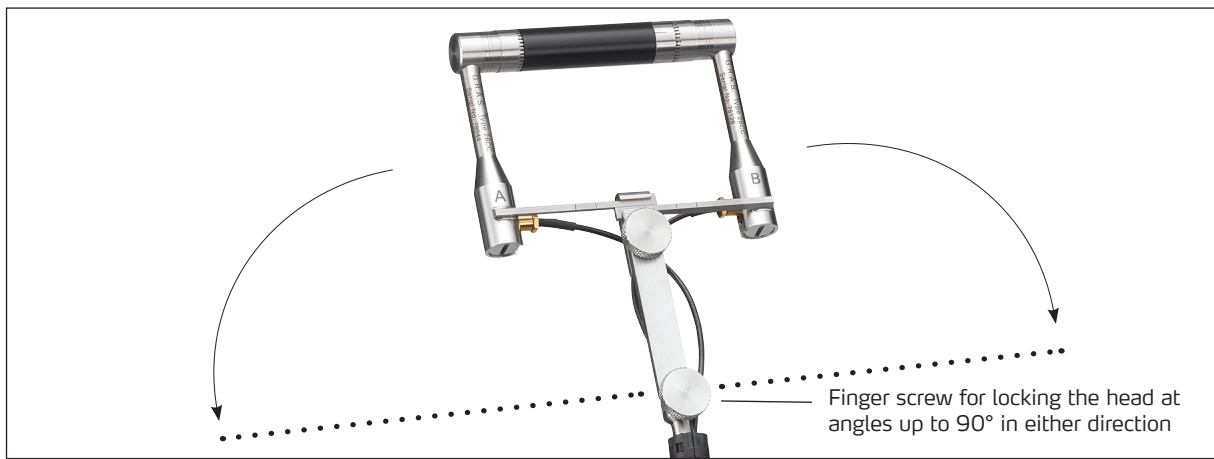

**Fig. 4.** Locking the probe head at an angle.

## Using the Probe

### Selecting Spacer

To cover the desired frequency range, the probe must be fitted with a spacer of the appropriate length according to the guidelines shown in Fig. 5.

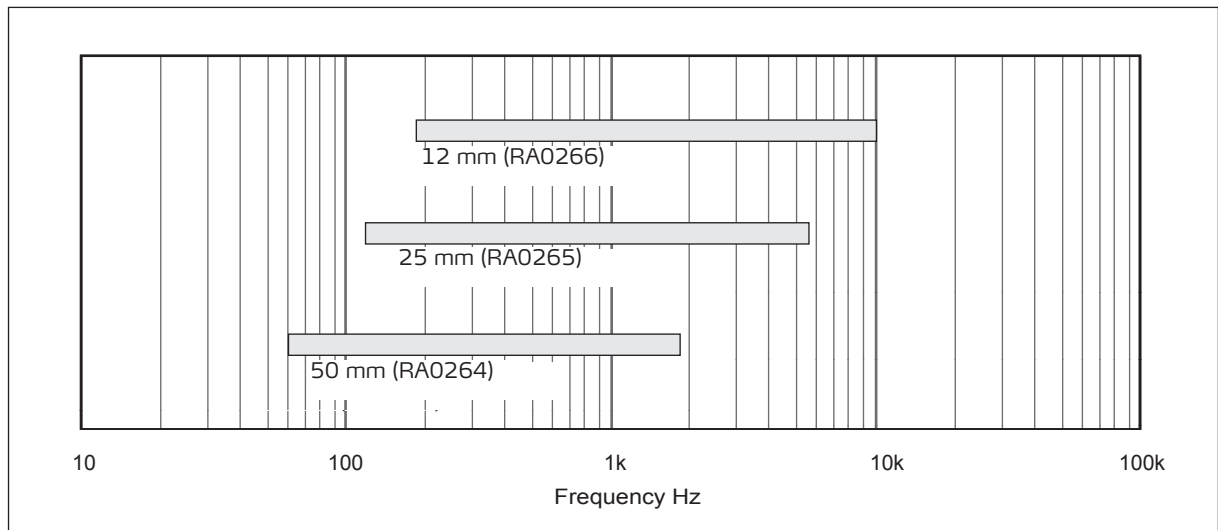

Fig. 5. Frequency ranges covered by the various spacer lengths.

### Sound-intensity Axis

A and B refer to the two probe channels: Channel A is reserved for the leading microphone, i.e. the microphone first struck by the acoustic wave front. The wave front travelling from microphone A to microphone B is interpreted as a positive component of the sound intensity.

Fig. 6 illustrates the origin and direction of positive sound-intensity vectors. Positive direction is always from microphone A to microphone B. The origin of the sound-intensity axis is always located in the geometric centre of the probe microphone pair.

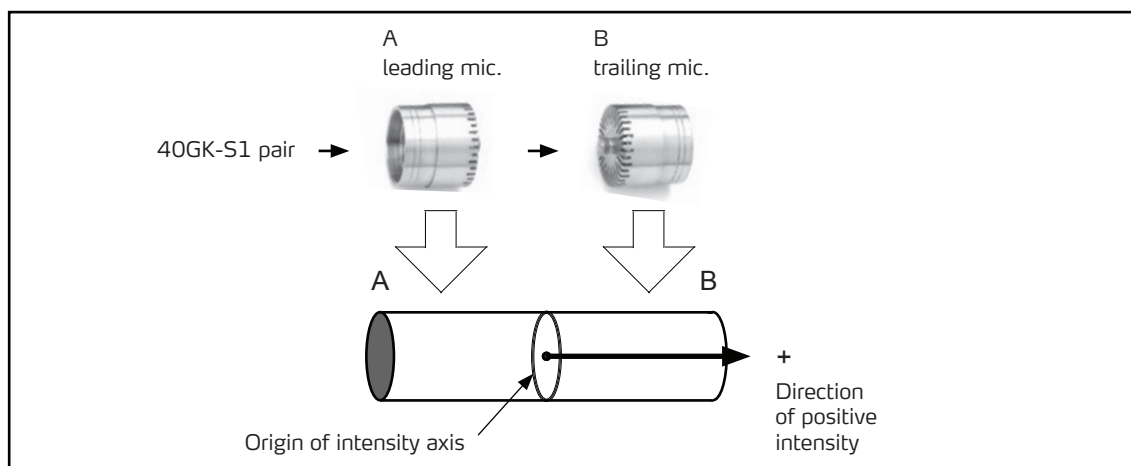

Fig. 6. Showing the microphones 'A' and 'B' which correspond with channels A and B respectively. 'A' is the leading microphone and is struck first by a sound wave.

## Calibration

### Preparing for Calibration

Before calibration, the microphones must be removed from the probe head to make it possible to mount them in a two-port calibration coupler or in a sound intensity calibrator.

After calibration, microphones and preamplifiers must be assembled in the same positions as before and during calibration.

The self-adhesive labels EM0065 are part of the delivery to make this easy and can be used to identify channel A and B respectively.



**Fig. 7.** Releasing the cable connectors from the holder assembly.

Removing the cables from the holder assembly:

1. Pull up the probe head.
2. Remove the screws from the bottom of both the holders (A and B).
3. Slide out the cable as shown in Fig. 7.

Now you can remove the spacers and reconnect the microphones+preamplifiers to the cables, ready for mounting in the RA0024 Two-port Calibration Coupler or the 51AB Sound Intensity Calibrator.

## Checking the Sensitivity and P-I Index using a Pistonphone

### Checking the Sensitivity

Check the sensitivity of the microphones using a 42AP (recommended) or 42AA Pistonphone. Refer to the manual supplied with the pistonphone for instructions on using the pistonphone.

### Checking the P-I Index (Pressure Intensity)

Check the P-I index using the RA0024 Two-port Calibration Coupler and a pistonphone:

1. Dismount the standard ½" coupler.
2. Mount the RA0024 Two-port Calibration Coupler, and insert the two microphones into its ports. *The two microphones will be subjected to the same pressure level.*

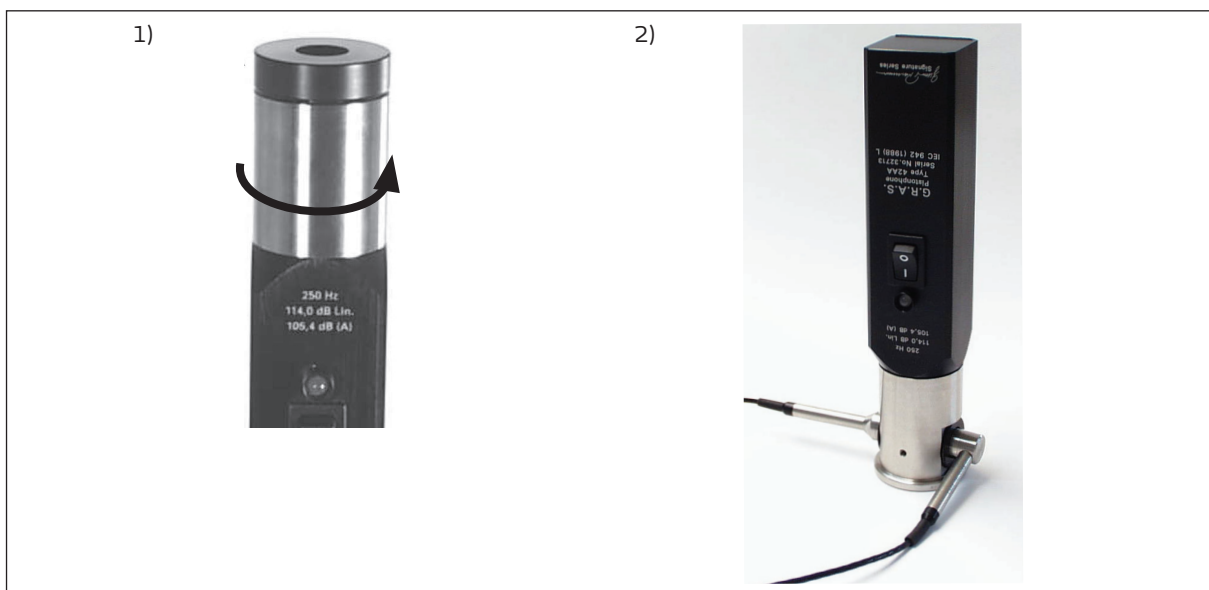

**Fig. 8.** RA0024 two port calibration coupler. NB: The microphones shown here are not the 40GK.

You will have to add the two-port correction factor for the RA0024 to the calibration value given for the pistonphone. The sound pressure level  $L_{2P}$  obtained in the two-port adapter is then:

$$L_{2P} = L_P + L_C$$

$L_P$ : normal pistonphone level corrected for the barometric pressure  
 $L_C$ : two-port correction factor (nominal 8.0 dB)

Two-port correction factor (nominal):	8.0 dB
Nominal Frequency	250 Hz

**Important:** 42AP automatically displays the barometric correction factor. If you are using 42AA, you must measure the barometric pressure separately.

## Checking the Probe's P-I Index using a Sound Intensity Calibrator

The P-I (Pressure Intensity) index of the sound intensity microphone pair and preamplifiers can be checked using the 51AB Intensity Calibrator – proceed as follows:

1. Mount the intensity microphones on their preamplifiers.
2. Connect the preamplifier outputs to the sound-intensity analyzer.
3. Insert the microphones into the holes at the ends of the Sound Intensity Calibrator, making sure to push them all the way in.
4. Set the intensity analyzer to measure intensity corresponding to a 25 mm microphone spacing.
5. Apply a signal<sup>1</sup> to the BNC input of the Sound Intensity Calibrator (signal must not exceed 1 V RMS).
6. Set the analyzer to mean pressure mode, and measure the result in decibels re. 20  $\mu$ Pa.
7. Set the analyzer to intensity mode and measure the result in decibels re.  $10^{-12}$  W/m<sup>2</sup>.

The P-I index of the intensity probe is then the difference, in decibels, of these two results. For frequencies equal to or above 300 Hz, this should be at least 29 dB.

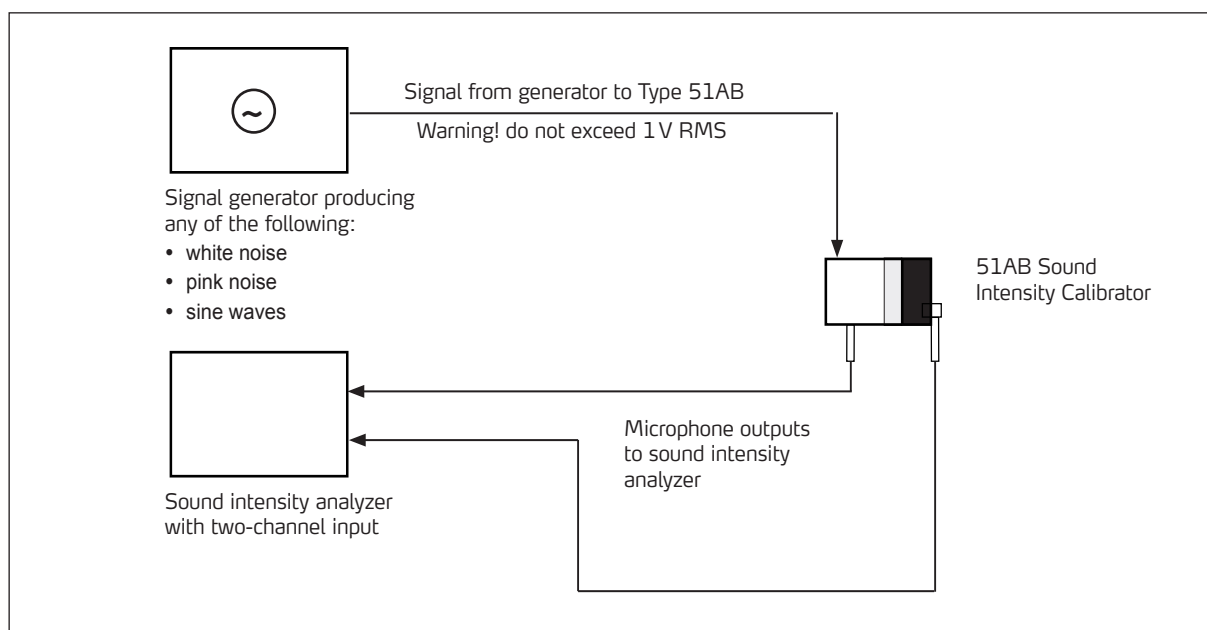

**Fig. 9.** Setup with signal generator and sound intensity analyzer.

<sup>1</sup> White-noise, pink-noise or a sine wave.

## Ordering Information

Included Items	Part number
Rugged Probe Head	RA0213
Pair of phase matched ½" microphones	40GK-S1
2 pcs Right-angled adapters	RA0001
Spacer cup	GR0040
12 mm spacer	RA0266
25 mm spacer	RA0265
50 mm spacer	RA0264
Pair of ¼" preamplifiers	26CC-Set
2 pcs SMB to Microdot cable	AA0068
2 pcs Adapter Microdot female-female	AE1038
2 pcs Microdot-BNC extension cable	AA0070
Set of self adhesive labels for channel identification (A, B)	EM0065
Handle	AI0044
Windscreen	AM0376

Optional Accessories	Part Number
12-pin LEMO Extension Cable, 3 m (female-male)	AA0072
12-pin LEMO Extension Cable, 10 m (female-male)	AA0071

### For calibration

Pistonphone with built-in barometer and thermometer (recommended)	42AP
Pistonphone	42AA
Two-port Calibration Coupler (for 42AP and 42AA Pistonphones)	RA0024
Intensity Calibrator	51AB

## Specifications and Warranty

### Specifications

Sound-intensity microphone pair 40GK-S1, phase-matched	½" Free-field
Preamplifiers 26CC	Phase-matched
Frequency response and phase-matching	IEC 61043 class 1
Weight	0.4 kg (0.9 lbs)
Length	42 cm
Frequency range	
with 50 mm spacer	60 Hz – 1.5 kHz
with 25 mm spacer	120 Hz – 5 kHz
with 12-mm spacer	200 Hz – 10 kHz

### Calibration

Before leaving the factory, all G.R.A.S. products are calibrated in a controlled laboratory environment using traceable calibration equipment.

We recommend a yearly recalibration at minimum, depending on the use, measurement environment, and internal quality control programs.

### Warranty

All G.R.A.S. products are made of high-quality materials that will ensure life-long stability and robustness. The 50GI-P is delivered with a 2-year warranty. Damaged diaphragms in microphones can be replaced.

The warranty does not cover products that are damaged due to negligent use, an incorrect power supply, or an incorrect connection to the equipment.

### Service and Repairs

All repairs are made at G.R.A.S. International Support Center located in Denmark. Our Support Center is equipped with the newest test equipment and staffed with dedicated and highly skilled engineers. Upon request, we make cost estimates based on fixed repair categories. If a product covered by warranty is sent for service, it is repaired free of charge, unless the damage is the result of negligent use or other violations of the warranty. All repairs are delivered with a service report, as well as an updated calibration chart.

Manufactured to conform with:

CE marking directive:  
93/68/EEC



WEEE directive:  
2002/96/EC



RoHS directive:  
2002/95/EC

