

Instruction Manual

G.R.A.S. 67HA 1 m Sound Power Hemisphere Kits

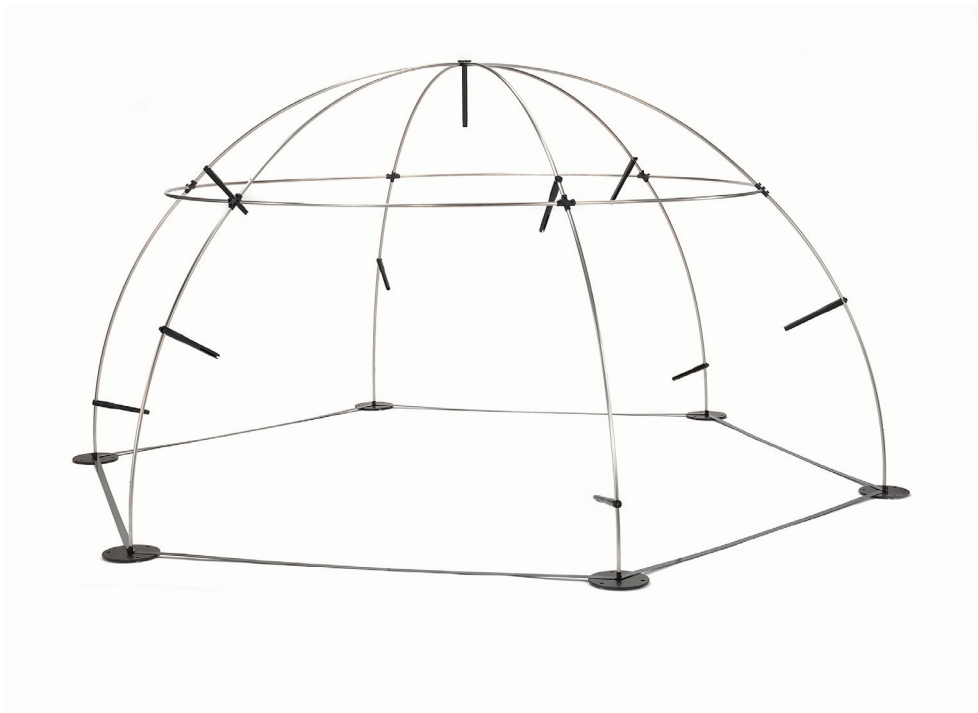

Revision History

Any feedback or questions about this document are welcome at gras@gras.dk.

Revision	Date	Description
1	11 August 2014	First release
2	28 October 2015	Caution about the use of non-G.R.A.S. cables added to the section "Mounting Microphone Sets and Cables"
3	10 December 2015	Number of cable clips included in the delivery corrected.
4	15 August 2016	Configuration naming on page 25 corrected (67HA-03 and 67HA-08)
5	4 July 2017	42AG substituted for the obsolete 42AB
6	10 November 2017	Color coding for 4 and 10 channel versions updated

Copyright Notice

© 2016-17 G.R.A.S. Sound & Vibration A/S

www.gras.dk

Any technical documentation that is made available by G.R.A.S. is the copyrighted work of G.R.A.S. and is owned by G.R.A.S.

The content in this document is subject to change without notice. G.R.A.S. Sound & Vibration A/S is not liable or responsible for any errors or inaccuracies that may appear in this document.

Trademarks

Any product names mentioned in this document may be trademarks or registered trademarks of their respective companies and are hereby acknowledged.

Contents

Introduction.....	5
Standards	5
Applications	5
Plug & Play	5
Holders and Cables	5
Delivered Items for 1 m Hemisphere	6
Hemisphere Structure.....	6
4-channel Configurations	7
10-channel Configurations	8
20-channel Configurations	9
Assembling the Hemisphere – Overview	10
Assembling the Hemisphere Structure	12
Introduction.....	12
Assembling the A-Layer (Bottom)	14
Assembling the B-Layer (Top).....	15
Assembling the Circle	16
Finishing the Assembly of the Structure	17
Mounting Microphone Sets and Cables	18
Mounting the Microphone Holders	18
Mounting Microphone Sets and Cables	21
Technical Specifications.....	22
Ordering Information.....	23
4-Channel Hemispheres	23
10-Channel Hemispheres	24
20-Channel Hemispheres	25
Accessories	26
Calibration, Warranty and Service.....	27
Verification and Calibration	27
Warranty.....	27
Service and Repairs.....	27



Introduction

If you have ever tried to configure and use a sound power setup based on microphones mounted on single tripods around your DUT, you will surely appreciate G.R.A.S.' new sound power hemisphere. The hemisphere will hold and position the measurement microphones according to the standards and has been designed with focus on your workflow; it is very easy to assemble and it is easy to position and access the DUT. Furthermore, in best G.R.A.S. tradition it is optimized acoustically for correct and repeatable measurement data.

The structure is made portable to achieve a high degree of freedom of location. This, combined with the easy, tool-less assembly in minutes, enables you to save expensive hemi-anechoic chamber time and to offer on-site sound power diagnostics.

Standards

The G.R.A.S. 67HA 1 m Sound Power Hemisphere is compliant with the ISO 3744, 3745 and 3746 (ANSI S12.54, S12.55, S12.56) standards and accommodate for 4, 10 and 20 microphone positions. These are clearly marked to ease the mounting and maintain measurement repeatability.

Applications

Depending on the size and the emitted acoustic level of the DUT, the hemisphere will allow sound power measurements on everything from small sized personal electronics to office machines and IT products, household appliances, power tools and smaller engines. The only restriction is that the characteristic dimension of the DUT may be no more than half the measurement radius. See the aforementioned standards for further details.

Plug & Play

The microphone sets can be connected directly to all professional measurement systems and are as indicated available for both CCP and 7-pin LEMO inputs. If your system platform supports intelligent transducers according to IEEE 1451.4 (TEDS), the system can be set up to identify the microphone properties and position in the array.

Holders and Cables







The pre-configured hemispheres are delivered with microphone set holders that will fit all 3 microphone types. Respective cables and cable clips are included.

Delivered Items for 1 m Hemisphere

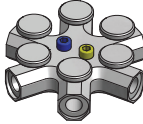

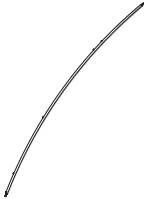

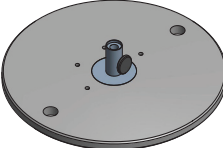

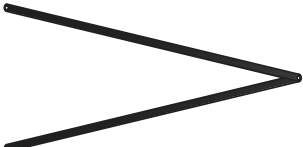









The G.R.A.S. 67HA 1 m Hemisphere is delivered in two cases, one containing the parts for the structure, microphone holders, cables and cable clips, the other containing the parts for configuring the hemisphere with microphone sets and cables.

It can be ordered for delivery in two flight cases, for further information, refer to "Accessories" on page 26.

















Hemisphere Structure

Delivered Items for 1 m Hemisphere Structure			
	6-pole Top Connecting Piece RA0254	4-pole Connecting Piece 6 x RA0255	
	Vertical Pole 6 labeled A1 to A6 6 labeled B1 to B6	Horizontal Pole 6 x GR156K	
	Foot 6 x RA0253	Bottom Strip 6 x RA0292	
	Finger Screws (spare, 5 of each) for: <i>Microphone Holders and Connecting Pieces</i>	Strip Set for Center Location RA0293	

4-channel Configurations











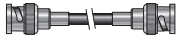

Delivered Microphones and Accessories for 4-Channel Configuration ISO 3746:2010 / ANSI S12.56			
G.R.A.S. 67HA-04 with CCP Microphone Sets			
	½" CCP Microphone Set 4 x 46AE	10 m Cable, BNC to BNC 4 x AA0037	
	Microphone Holder incl. finger screw 3 x RA0259	Spacer for Microphone Holder, 28 mm 4 x GR1572	
	Top Microphone Holder RA0261	Cable Clip 50 x KE0130	
G.R.A.S. 67HA- 01 with LEMO Microphone Sets			
	½" LEMO Microphone Set 4 x 46AF	10 m Cable LEMO to LEMO 4 x AA0009	
	Microphone Holder incl. finger screw 3 x RA0259	Spacer for Microphone Holder, 18 mm 4 x GR1571	
	Top Microphone Holder RA0261	Cable Clip 50 x KE0130	
G.R.A.S. 67HA-07 with Low Noise Microphone Sets			
	½" Low-noise Microphone Set 4 x 40HL	10 m Cable, LEMO to LEMO 4 x AA0009	
	Microphone Holder incl. finger screw 3 x RA0259	Cable Clip 50 x KE0130	
	Top Microphone Holder RA0261		

10-channel Configurations

Delivered Microphones and Accessories for 10-Channel Configuration			
ISO 3744:2010 / ANSI S12.54			
G.R.A.S. 67HA-05 with CCP Microphone Sets			
	½" CCP Microphone Set 10 x 46AE	10 m Cable, BNC to BNC 10 x AA0037	
	Microphone Holder incl. finger screw 9 x RA0259	Spacer for Microphone Holder, 28 mm 10 x GR1572	
	Top Microphone Holder RA0261	Cable Clip 50 x KE0130	
G.R.A.S. 67HA- 02 with LEMO Microphone Sets			
	½" LEMO Microphone Set 10 x 46AF	10 m Cable LEMO to LEMO 10 x AA0009	
	Microphone Holder incl. finger screw 9 x RA0259	Spacer for Microphone Holder, 18 mm 10 x GR1571	
	Top Microphone Holder RA0261	Cable Clip 50 x KE0130	
G.R.A.S 67HA-08 with Low Noise Microphone Sets			
	½" Low-noise Microphone Set 10 x 40HL	10 m Cable, LEMO to LEMO 10 x AA0009	
	Microphone Holder incl. finger screw 9 x RA0259	Cable Clip 50 x KE0130	
	Top Microphone Holder RA0261		



20-channel Configurations

Delivered Microphones and Accessories for 20-Channel Configuration ISO 3745:2010 / ANSI S12.55			
G.R.A.S. 67HA-06 with CCP Microphone Sets			
	½" CCP Microphone Set 20 x 46AE	10 m Cable, BNC to BNC 20 x AA0037	
	Microphone Holder incl. finger screw 20 x RA0259	Spacer for Micro- phone Holder, 28 mm 20 x GR1572	
	Cable Clip 50 x KE0130		
G.R.A.S. 67HA-03 with LEMO Microphone Sets			
	½" LEMO Microphone Set 20 x 46AF	10 m Cable LEMO to LEMO 20 x AA0009	
	Microphone Holder incl. finger screw 20 x RA0259	Spacer for Micro- phone Holder, 18 mm 4 x GR1571	
	Cable Clip 50 x KE0130		
G.R.A.S 67HA-09 with Low Noise Microphone Sets			
	½" Low-noise Microphone Set 20 x 40HL	10 m Cable, LEMO to LEMO 20 x AA0009	
	Microphone Holder incl. finger screw 20 x RA0259	Cable Clip 50 x KE0130	

Assembling the Hemisphere – Overview

The G.R.A.S. 1 m Hemisphere for sound power measurements consists of a basic structure common to all applications. This structure can be configured for 4-channel, 10-channel and 20-channel measurements. Below is shown a quick overview of the assembly of the hemisphere and the mounting of microphones for a 10-channel configuration. A detailed description of the assembly is given in the following sections.

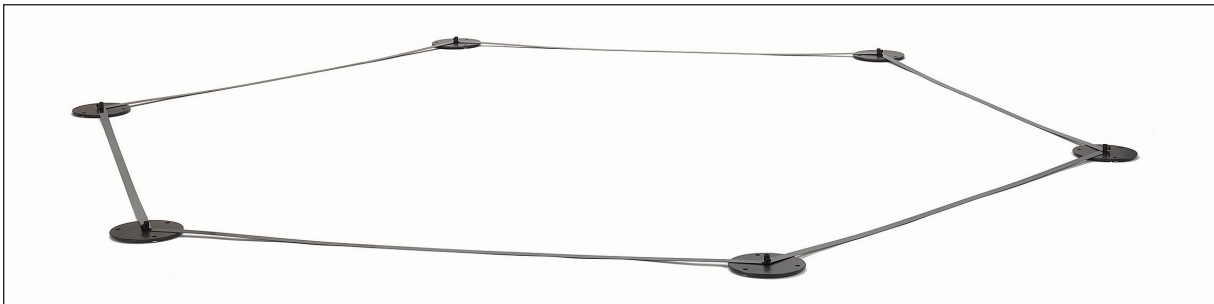

Fig. 1. The basic hexagonal layer.

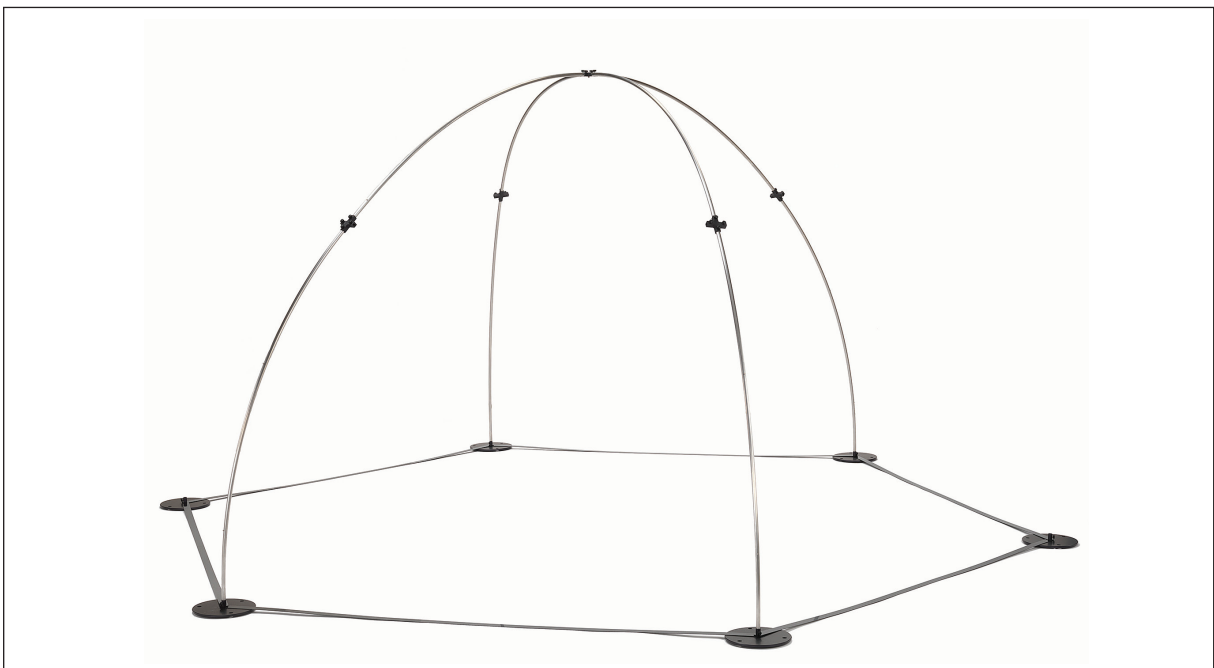

Fig. 2. The basic layer and four out of six legs of the vertical structures assembled.



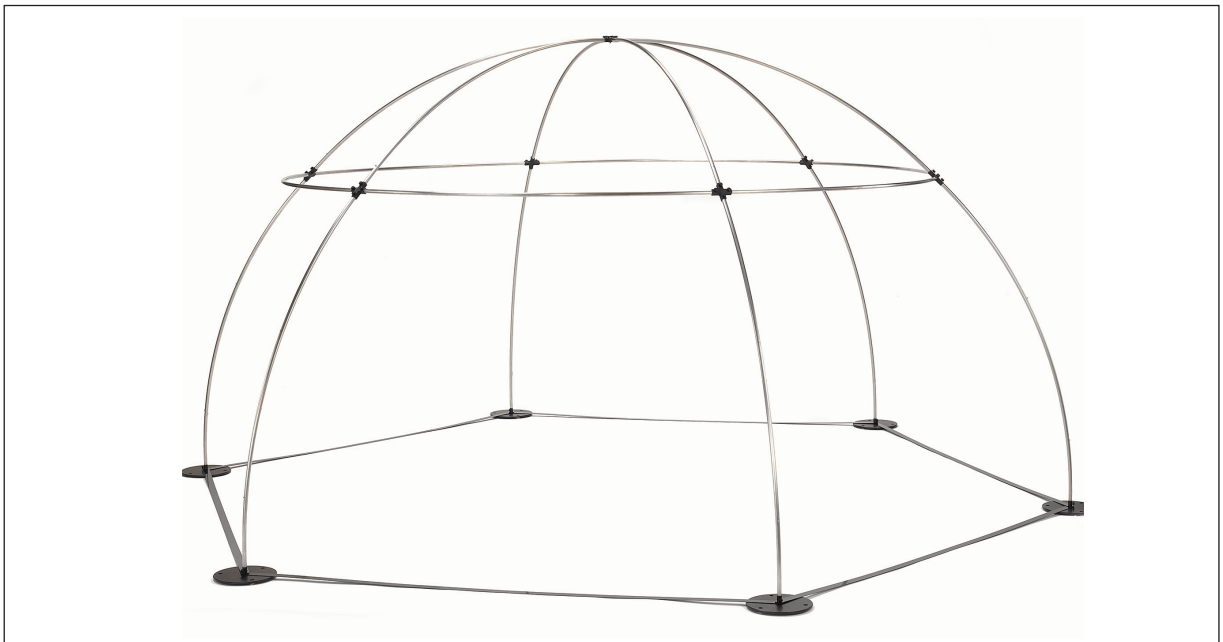

Fig. 3. The assembled structure ready for configuration.

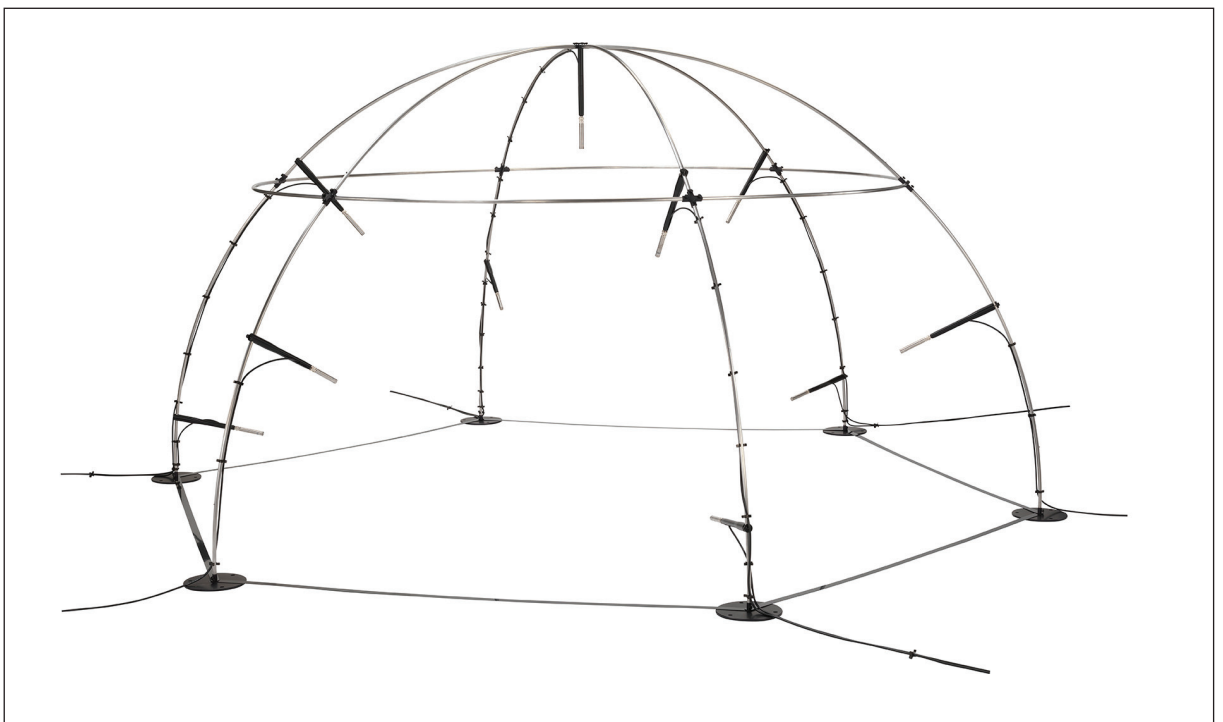

Fig. 4. The hemisphere structure mounted with microphones and cables for a 10-channel setup.

Assembling the Hemisphere Structure

Introduction

The Hemisphere consists of a ground layer and vertical and horizontal poles:

- The ground layer consists of six feet and six connecting strips.
- The A-layer consists of six vertical poles attached to the feet, labeled A1 to A6.
- The horizontal circle consists of six poles and six 4-pole connecting pieces.
- The top-B layer consists of six vertical poles labeled B1 to B6, and a 6-pole connecting piece.

It can be assembled without tools by one person. All connections are fastened with finger screws.

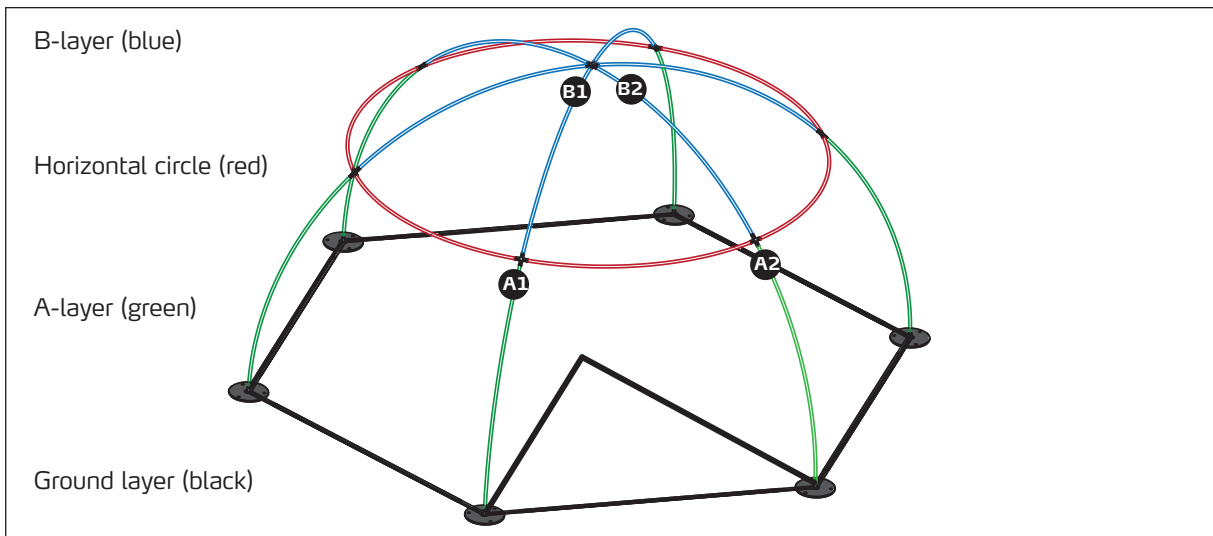

Fig. 5. The hemisphere structure.

The vertical poles and the top connecting piece are furnished with colored bolts marking the positions for the microphones according to the ISO and ANSI standards for sound power measurements.

The yellow bolts indicate the positions for 4-channel measurements, the blue for 10-channels and the red for 20 channels.

Important. To ensure correct positioning of the colored bolts you must:

- Mount the poles A1 to A6 counterclockwise.
- Align the A-layer and the B-layer (A1 with B1 and so on).

- Ensure that the labeled end of the poles point upwards.

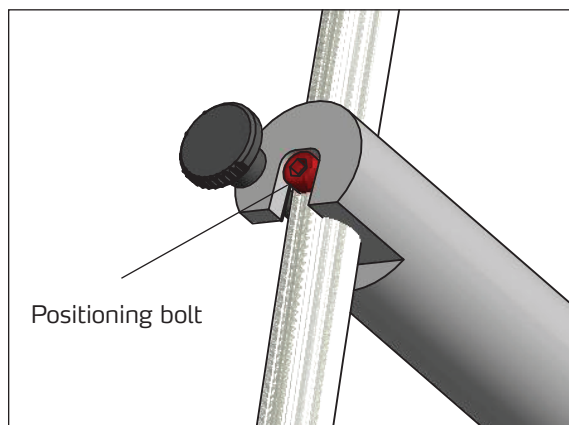

Fig. 6. The Microphone Holders are positioned over colored bolts mounted on the vertical poles.

Assembling the Ground Layer

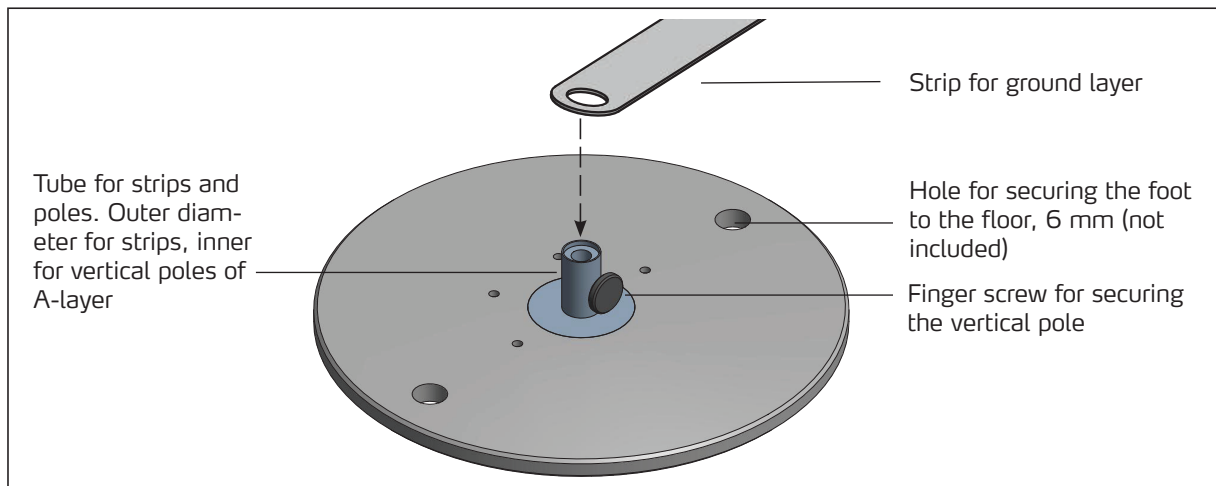

Fig. 7. A Hemisphere foot showing the details for connections to vertical poles and strips.

1. Remove the finger screws from the tubes of the feet.
2. Slide two strips down over each of the vertical tubes until the circle is complete.
3. Mount the strip set for center location over two of the feet.
4. Mount the screws again (to avoid losing them). Do not tighten, but leave room for the vertical poles to slide into the holes.

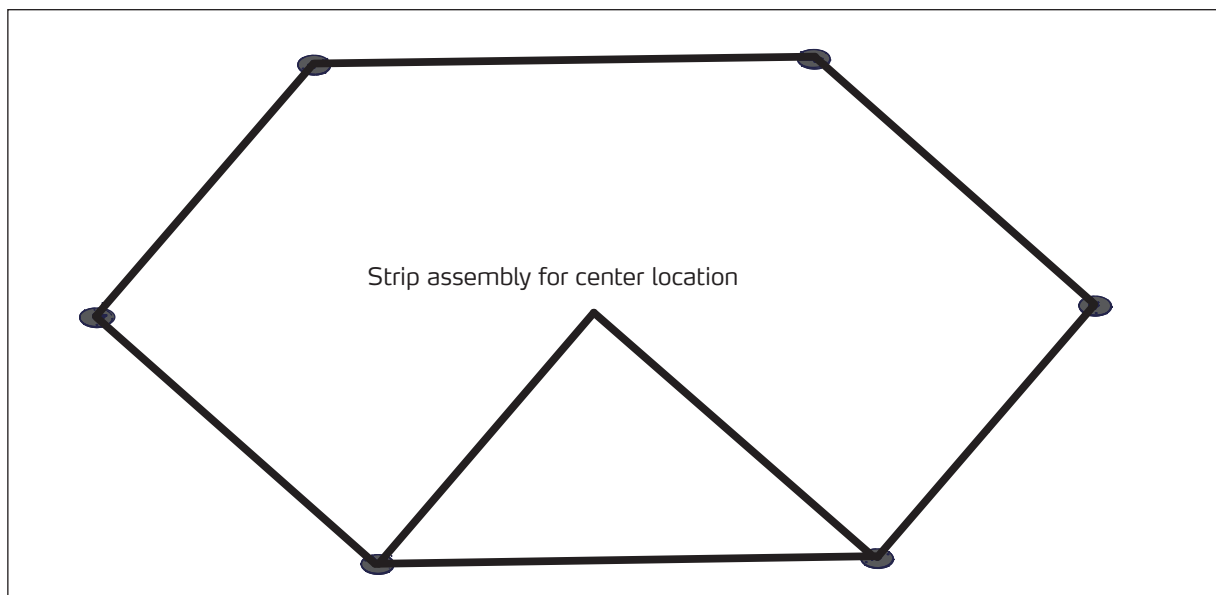

Fig. 8. The finished ground layer.

Assembling the A-Layer (Bottom)

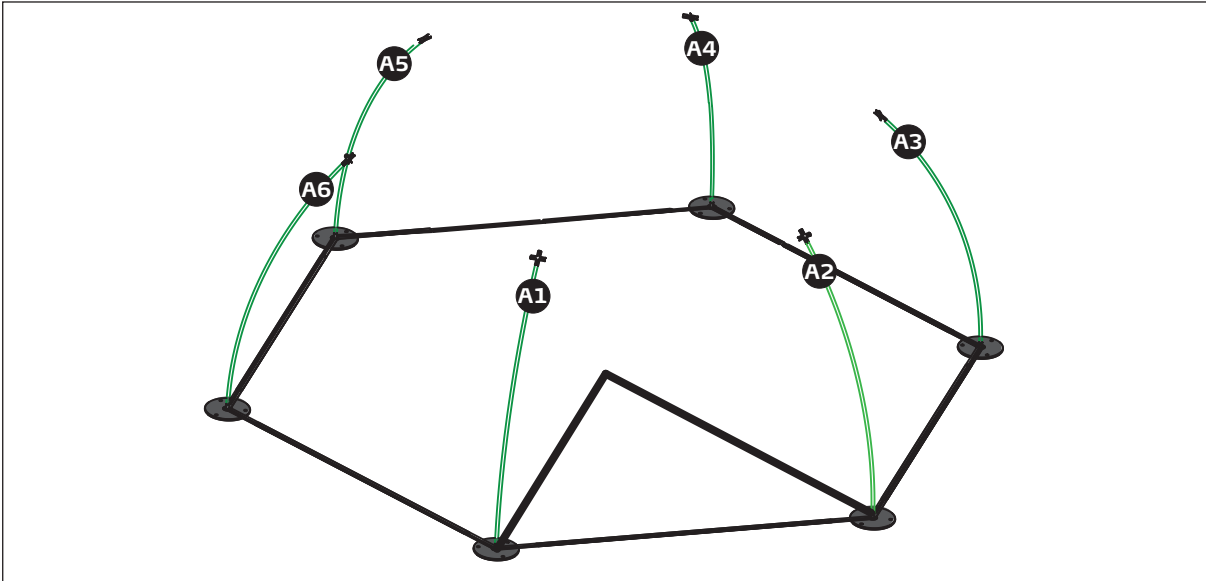

Fig. 9. The A-layer vertical poles mounted in the feet.

Mounting the Vertical Poles and 4-pole Connecting Pieces

1. Slide the vertical pole labeled A1 with the label end upwards into one of the feet.
2. Tighten the finger screw lightly to assure some clearance for angular adjustment of poles and connecting pieces in the next steps. See Fig. 10-1.
3. Repeat steps 1 & 2 for the poles A2 to A6 in counterclockwise sequence, as shown in Fig. 9.
4. Slide the six 4-pole connecting pieces onto six the pole ends (Fig. 10-2).
5. Tighten the lower finger screws lightly (Fig. 10-3).

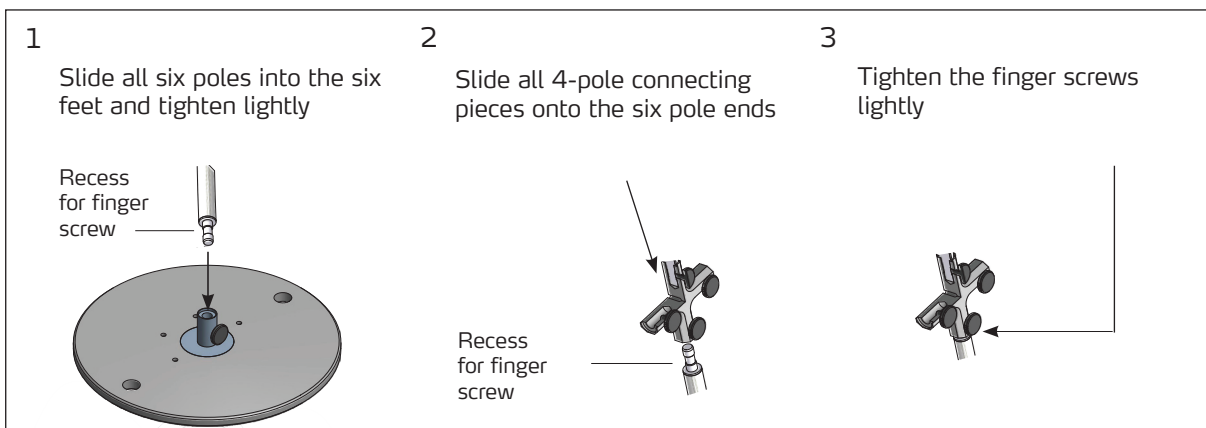

Fig. 10. Mounting the lower poles and the 4-pole connecting pieces.

Assembling the B-Layer (Top)

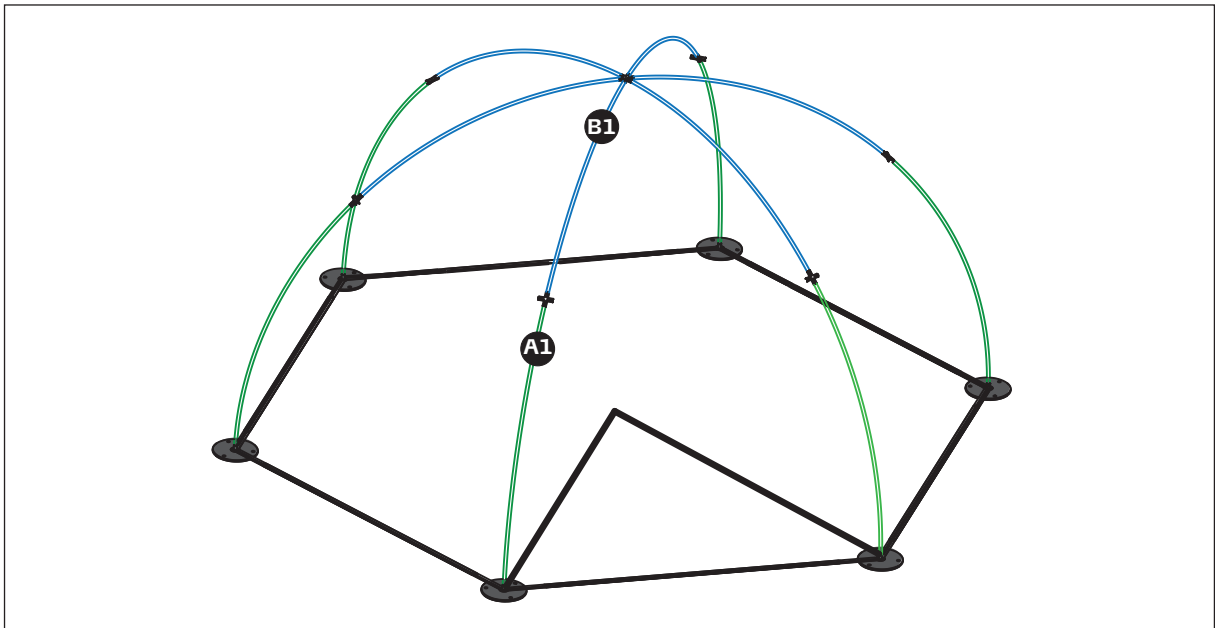

Fig. 11. The 1m Hemisphere with all vertical poles assembled.

Mounting the Vertical Poles and the top Connecting Piece

1. Slide the six vertical poles B1 to B6 into the 4-pole connecting pieces with the labeled end pointing upwards, and tighten lightly. See Fig. 12-1. The pole labeled B1 must be flush with A1 and so on.
2. Slide the poles into the top connecting piece and tighten the finger screws lightly. See Fig. 12-2.

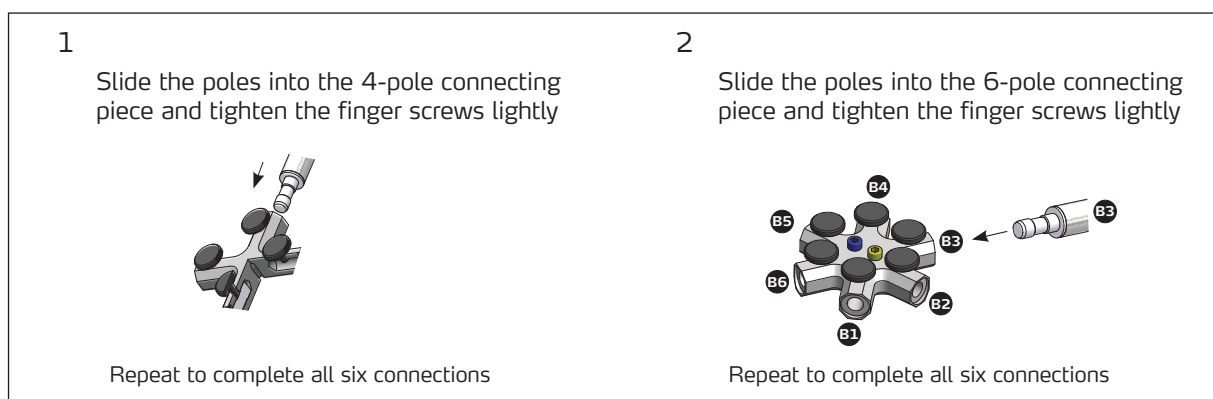

Fig. 12. Mounting the upper poles and the top 6-pole connecting piece.

Assembling the Circle

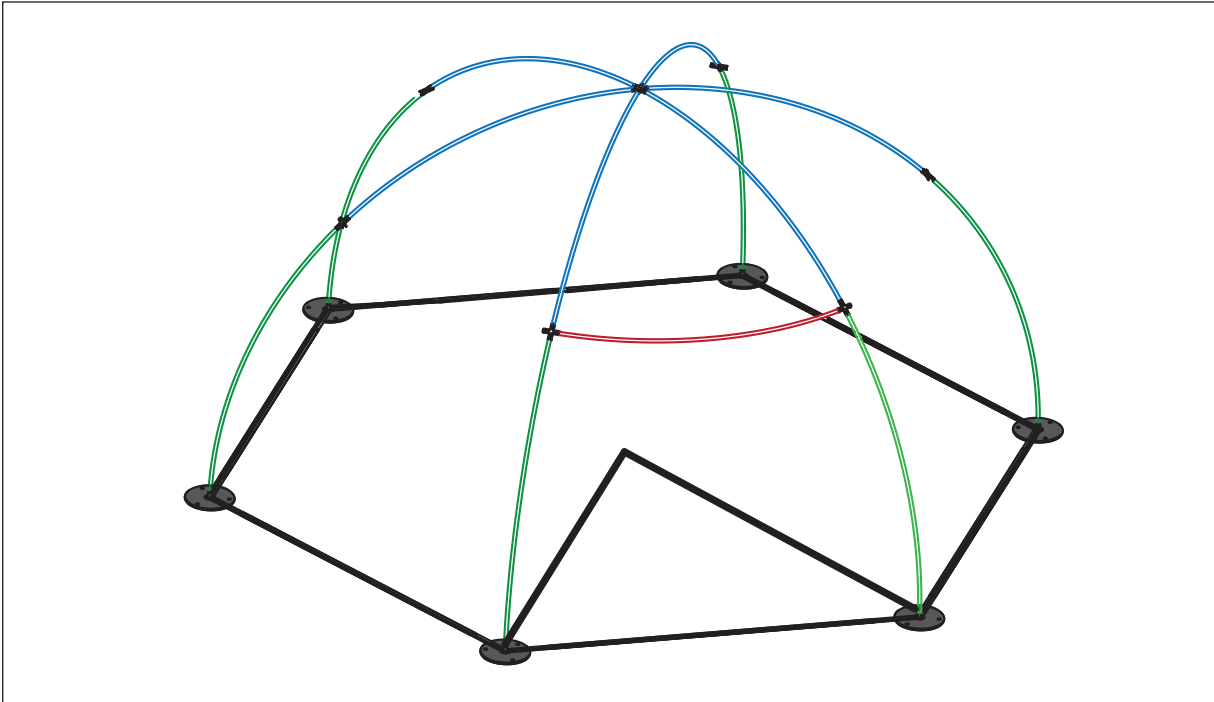

Fig. 13. First step of the assembly of the circle.

Assembling the Circle

The circle consists of six identical poles. Their purpose is solely to stabilize the structure and they can therefore be sequenced at will. When finished, the structure will look as shown in Fig. 15.

1. Slide the poles into the 4-pole connecting pieces.
2. Tighten the finger screws lightly: Some clearance is needed for final adjustment of poles and connecting pieces.

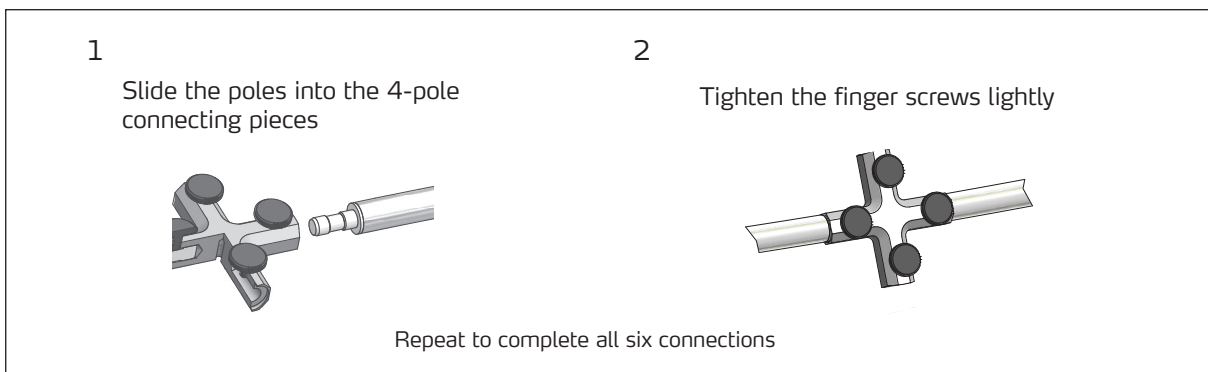

Fig. 14. Assembling the circle.

Finishing the Assembly of the Structure

When all poles and connecting pieces have been assembled, you need to fine adjust the orientation of all poles and tighten all finger screws.

When mounted correctly, the hemisphere will present a smooth structure with a level horizontal circle and smooth vertical curves. However, as all connecting pieces are straight, minor deviations from perfect circles must be expected.

The positioning and adjustment system for the microphones makes it possible to position the microphones very accurately in relation to the device under test. For information about fine adjustment of the positioning of the microphones, refer to Fig. 16 and Fig. 19.

Five extra finger screws for the connecting pieces are included in the delivery, so a number of extra screws will be in reserve when the structure has been assembled.

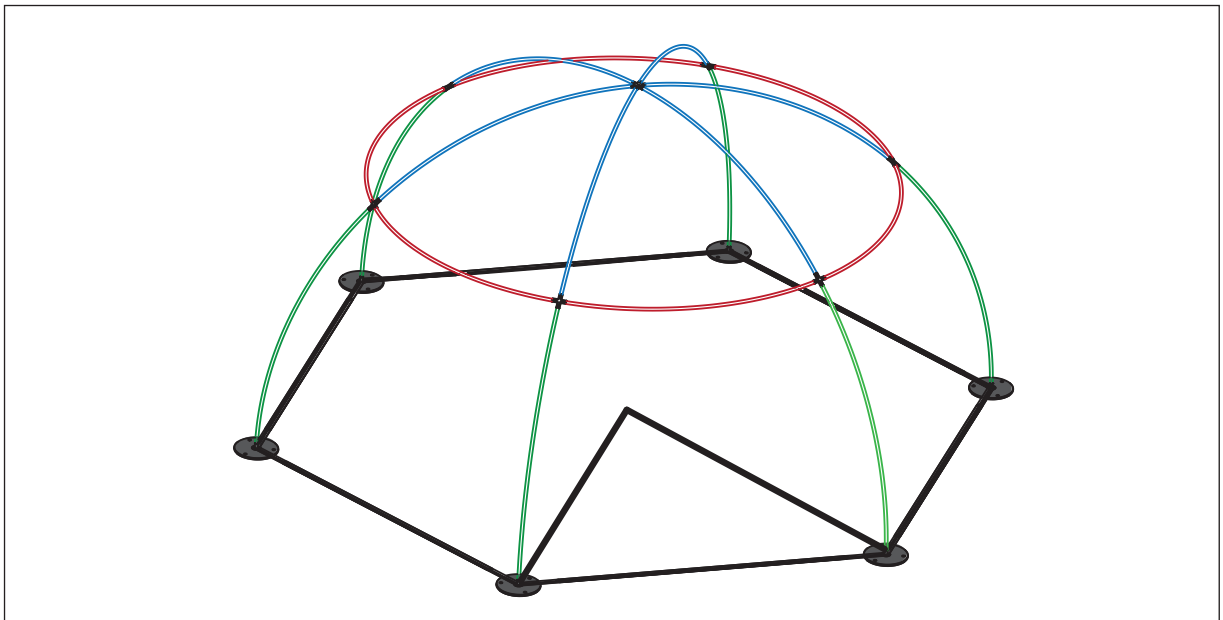

Fig. 15. The finished hemisphere structure.

Mounting Microphone Sets and Cables

Mounting the Microphone Holders

The hemisphere is designed for easy and repeatable 4-channel, 10-channel and 20-channel measurements:

- Clearly marked mounting points make it easy to mount the microphone sets in accordance with the ISO and ANSI standards.
- A flexible mounting system with adjustable holders and fixed spacers makes it easy to mount the microphone sets with the correct distance and angle to the hemisphere's center.

Mounting Points

The mounting points for 4, 10 and 20 channel measurements are identified by colored M3 bolts on the vertical poles, and – for 4 and 10 channel measurements – also on the top connecting piece.

The mounting points for 4 channels are located according to the ISO 3746:2010 (Table B.1) recommendation for microphone positions for a noise source over a reflecting plane. The mounting points for 10 and 20 channels are located according to the ISO 3744:2010 (Table B.2) and ISO 3745:2012 (Table E.2) recommendations for microphone positions for a broadband noise source.

For **4 channels**, positions 4, 5, 6 and 10 are marked with black bolts, the additional positions 14, 15, 16 and 20 are marked with grey bolts.

For **10 channels**, positions 1 to 10 are marked with blue and black positioning bolts, the additional positions 11 to 20 with yellow and grey bolts.

For **20 channels**, the positions 1 to 20 are marked with red bolts.

Channels	Standard	Key microphone positions		Additional positions	
4	ISO 3746:2010 - Table B.1 / ANSI S12.56		–		–
10	ISO 3744:2010 - Table B.2 / ANSI S12.54				
20	ISO 3745:2012 - Table E.2 / ANSI S12.55		–	–	–



Holders and Spacers

For all configurations, the same type of microphone holder is used. Spacers of different lengths are used to ensure that the three types of microphone sets – CCP, LEMO and LEMO Low-noise – can be mounted with the correct distance to the center.

Microphone Set	Spacer
46AE (CCP)	28 mm spacer
46AF (LEMO)	18 mm spacer
40HL (LEMO, Low Noise)	No spacer

Mounting Microphone Holders on Vertical Poles

1. Remove the finger screw from the end of the microphone holder assembly and slide the holder over the pole.
2. Slide the holder downwards until it is centered over the colored bolt.
3. Mount the finger screw and tighten it lightly.
4. Adjust the direction of the holder to point at the center of the hemisphere and tighten the finger screw.

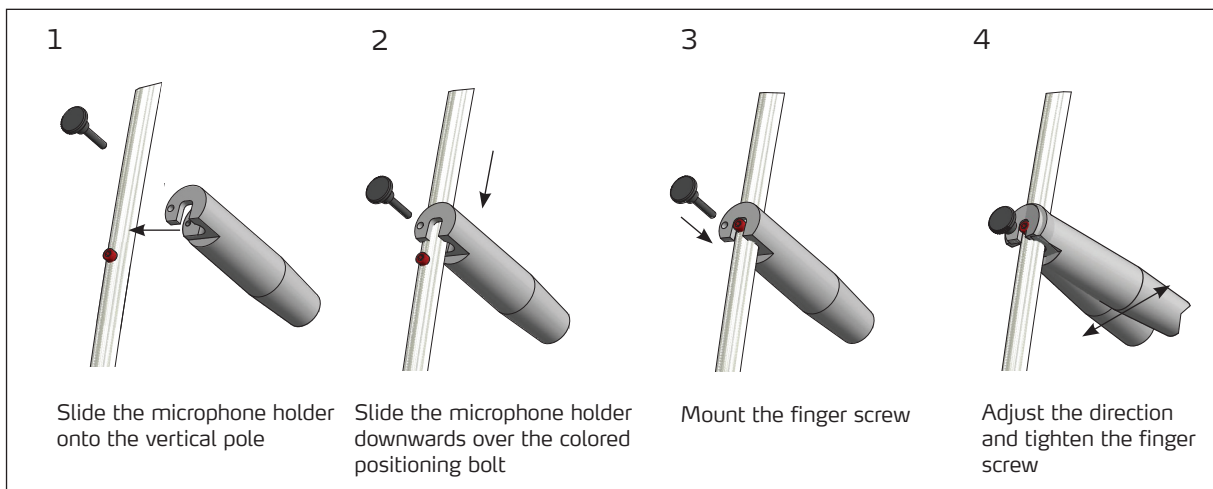

Fig. 16. Attaching a microphone holder to a vertical pole.

Mounting a Microphone Holder at the Top Center

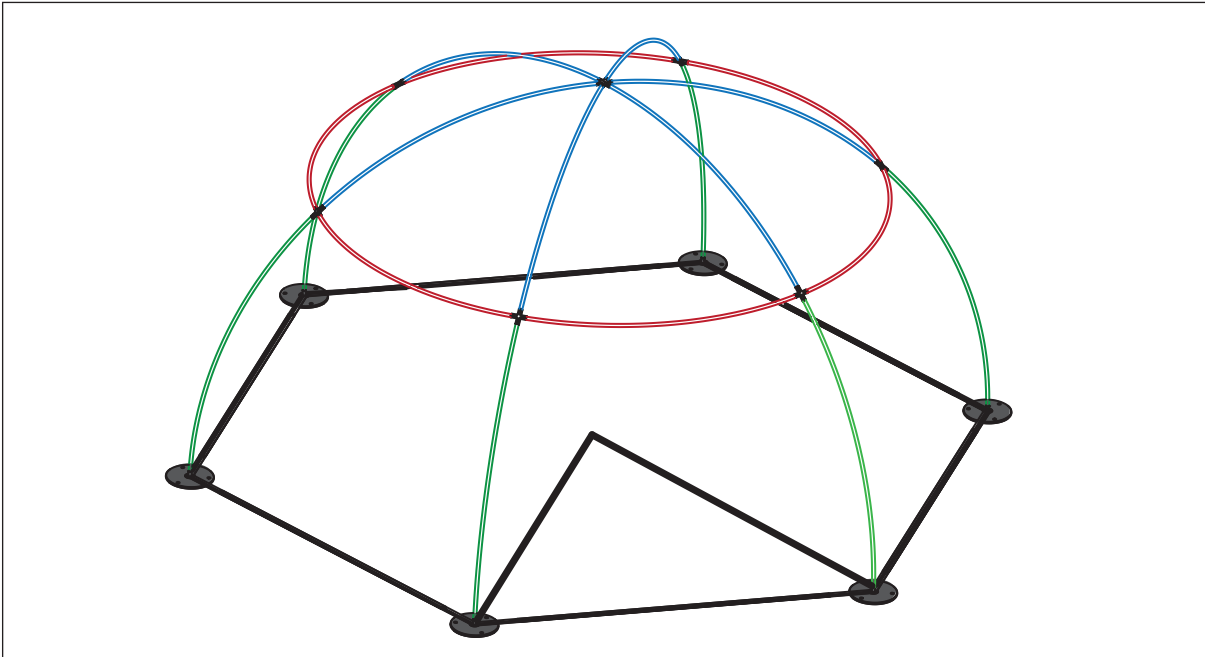

Fig. 17. For 4 and 10-channel configurations, the top microphone holder is attached to the top connector.

1. Screw the long top spacer onto the stud screw on the 6-pole connecting piece.
2. Slide a spacer onto the lower part of the Microphone Holder. For CCP Microphone sets, a 28 mm spacer is needed, for LEMO microphone sets an 18 mm spacer is needed. For the LEMO low-noise microphone sets, no spacer is needed.
3. Screw the lower part into the upper part.

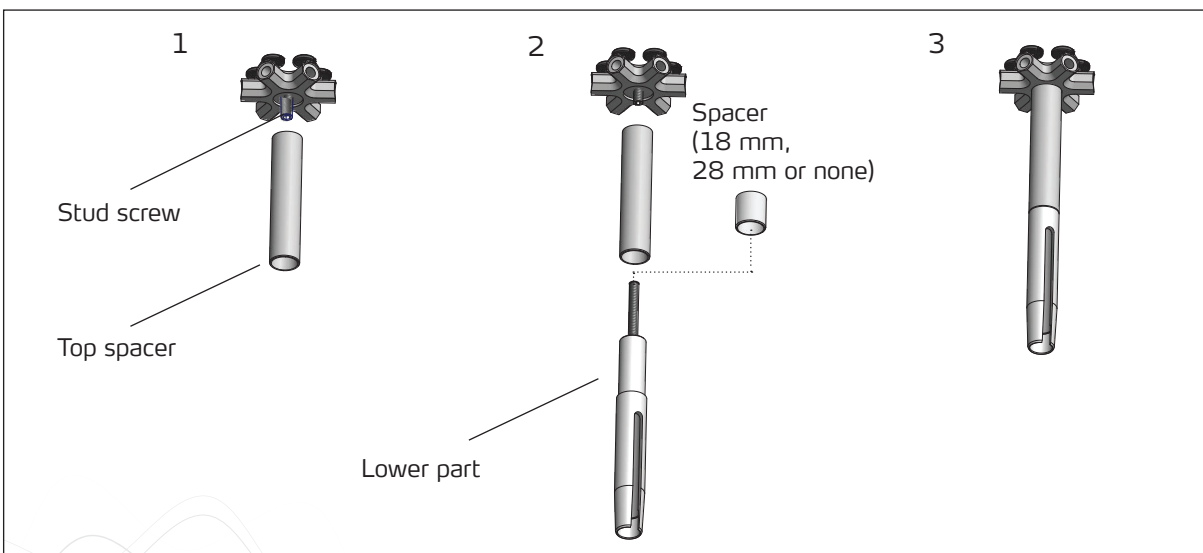

Fig. 18. Mounting and assembling the Top Microphone Holder.

Mounting Microphone Sets and Cables

The microphone sets are push fitted into the microphone holders until they bottom out. The slit in the lower part of the holder is used for the cable. The cables are fastened to the hemisphere poles with wire clips.

Caution. The microphone holders are designed specifically for G.R.A.S. cables. The cable must fit the slot in the holder, and cables from other vendors may be too thick and therefore cause damage, or may be impossible to position precisely. Therefore, we strongly recommend that only G.R.A.S. cables are used.

To mount the microphone sets and cables:

1. Connect a cable to the microphone set.
2. Push the microphone into the microphone holder while aligning the cable with the slit.
3. Guide the cable through the slit and push the assembly into the holder.
4. Secure the cable to the outside of the hemisphere's vertical poles with the cable clips.

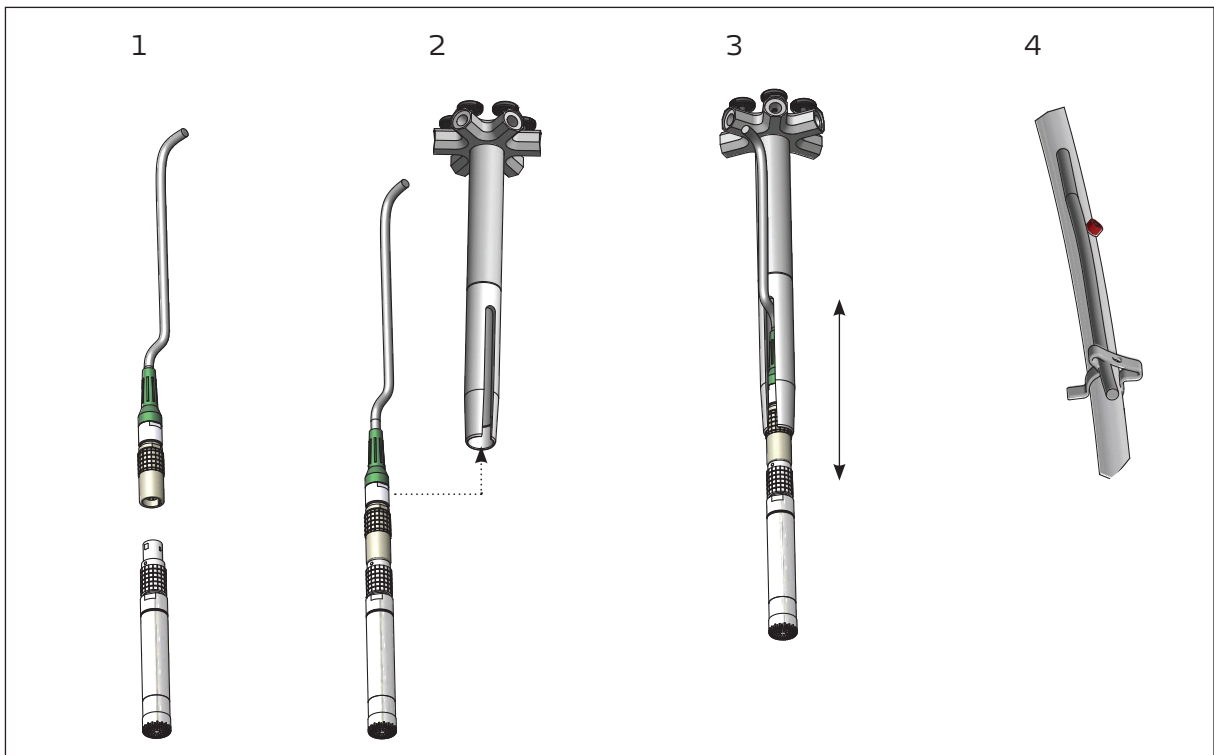

Fig. 19. Mounting a microphone set in a microphone holder.

This method applies for all three types of microphone sets – only the use of spacer on the microphone holder differs, see "" on page 18.

The distance to the center can be fine adjusted by how far into the holder you push the microphone set, see Fig. 19, 3.

Technical Specifications

Dimensions incl. Feet

Diameter	2714 mm
Height	1285 mm

G.R.A.S. 46AE 1/2" CCP Standard Microphone Sets

Frequency Range	3.15 Hz – 20 kHz
Dynamic Range	17 dBA – 138 dB
Sensitivity	50 mV/Pa

G.R.A.S. 46AF 1/2" LEMO Standard Microphone Sets

Frequency Range	3.15 Hz – 20 kHz
Dynamic Range	17 dBA – 154 dB
Sensitivity	50 mV/Pa

G.R.A.S. 40HL 1/2" LEMO Lownoise Microphone Sets

Frequency Range	6 Hz – 20 kHz
Dynamic Range	6,5 dBA – 110 dB
Sensitivity	900 mV/Pa

Ordering Information

4-Channel Hemispheres

(ISO 3746:2010/ANSI S12.56)

G.R.A.S 67HA-04 1 m 4 ch. CCP Sound Power Hemisphere

Included Items		Part Number
1 m Hemisphere Structure	1	AL0024-4
G.R.A.S. ½" CCP Standard Microphone Set	4	46AE
10 m BNC Cable*	4	AA0037
Microphone Holder	3	RA0259
Microphone Holder Spacer, 28 mm	4	GR1572
Top Microphone Holder	1	RA0261
Cable clips	50	KE0130

*Customer specified cable lengths can be ordered, refer to "Accessories" on page 26.

G.R.A.S 67HA-01 1 m 4 ch. LEMO Sound Power Hemisphere

Included Items		Part Number
1 m Hemisphere Structure	1	AL0024-1
G.R.A.S. ½" LEMO Standard Microphone Set	4	46AF
10 m LEMO Cable	4	AA0009
Microphone Holder	3	RA0259
Microphone Holder Spacer, 18 mm	4	GR1571
Top Microphone Holder	1	RA0261
Cable clips	50	KE0130

G.R.A.S 67HA-07 1 m 4 ch. Lownoise Sound Power Hemisphere

Included Items		Part Number
1 m Hemisphere Structure	1	AL0024-7
G.R.A.S. ½" LEMO Low-noise Microphone Set	4	40HL
10 m LEMO Cable	4	AA0009
Microphone Holder	3	RA0259
Top Microphone Holder	1	RA0261
Cable clips	50	KE0130

10-Channel Hemispheres

(ISO 3744:2010/ANSI S12.54)

G.R.A.S 67HA-05 1 m 10 ch. CCP Sound Power Hemisphere

Included Items		Part Number
1 m Hemisphere Structure	1	AL0024-5
G.R.A.S. ½" CCP Standard Microphone Set	10	46AE
10 m BNC Cable*	10	AA0037
Microphone Holder	9	RA0259
Microphone Holder Spacer, 28 mm	10	GR1572
Top Microphone Holder	1	RA0261
Cable clips	50	KE0130

*Customer specified cable lengths can be ordered, refer to "Accessories" on page 26.

G.R.A.S 67HA-02 1 m 10 ch. LEMO Sound Power Hemisphere

Included Items		Part Number
1 m Hemisphere Structure	1	AL0024-2
G.R.A.S. ½" LEMO Standard Microphone Set	10	46AF
10 m LEMO Cable	10	AA0009
Microphone Holder	9	RA0259
Microphone Holder Spacer, 18 mm	10	GR1571
Top Microphone Holder	1	RA0261
Cable clips	50	KE0130

G.R.A.S 67HA-08 1 m 10 ch. Lownoise Sound Power Hemisphere

Included Items		Part Number
1 m Hemisphere Structure	1	AL0024-8
G.R.A.S. ½" LEMO Low-noise Microphone Set	10	40HL
10 m LEMO Cable	10	AA0009
Microphone Holder	9	RA0259
Top Microphone Holder	1	RA0261
Cable clips	50	KE0130

20-Channel Hemispheres

(ISO 3745:2010/ANSI S12.55)

G.R.A.S 67HA-06 1 m 20 ch. CCP Sound Power Hemisphere

Included Items		Part Number
1 m Hemisphere Structure	1	AL0024-6
G.R.A.S. ½" CCP Standard Microphone Set	20	46AE
10 m BNC Cable*	20	AA0037
Microphone Holder	20	RA0259
Microphone Holder Spacer, 28 mm	20	GR1572
Cable clips	50	KE0130

*Customer specified cable lengths can be ordered, refer to "Accessories" on page 26.

G.R.A.S 67HA-03 1 m 20 ch. LEMO Sound Power Hemisphere

Included Items		Part Number
1 m Hemisphere Structure	1	AL0024-3
G.R.A.S. ½" LEMO Standard Microphone Set	20	46AF
10 m LEMO Cable	20	AA0009
Microphone Holder	20	RA0259
Microphone Holder Spacer, 18 mm	20	GR1571
Cable clips	50	KE0130

G.R.A.S 67HA-09 1 m 20 ch. Lownoise Sound Power Hemisphere

Included Items		Part Number
1 m Hemisphere Structure	1	AL0024-9
G.R.A.S. ½" LEMO Low-noise Microphone Set	20	40HL
10 m LEMO Cable	20	AA0009
Microphone Holder	20	RA0259
Cable clips	50	KE0130

Accessories

Item	Part Number
Pair of flight cases, with foam inserts	RA0276
G.R.A.S. Multifunction Sound Calibrator (94 dB and 114 dB)	42AG
G.R.A.S. Intelligent Pistonphone (114 dB)	42AP
G.R.A.S. 94dB Pistonphone Coupler for G.R.A.S. 42AP	RA0090
Cable for CCP Microphone Sets, custom length, XXXX = custom length in centimeters	AA0039- CLXXXX
Cable for LEMO Microphone Sets, custom length, XXXX = custom length in centimeters	AA0020-CLXXXX



Calibration, Warranty and Service

All included microphone sets are delivered with individual calibration charts including sensitivity values and frequency responses. These sensitivity values can be used directly in your system setup.

Verification and Calibration

For measurement chain verification, a reference sound source will be required. G.R.A.S. supplies 114 dB Sound Calibrators and Pistonphones for the standard microphone sets and a special 94 dB Pistonphone Coupler for the low-noise microphone sets.

Depending on the use and your internal quality control requirements we recommend that the sets are re-calibrated at least every second year.

Contact your G.R.A.S. Partner for options and services.

Warranty

All G.R.A.S. products are made of high-quality materials that will ensure life-long stability and robustness. The Hemisphere structure is delivered with a 5-year warranty.

The warranty for cables is 6 months.

The warranty does not cover products that are damaged due to negligent use, an incorrect power supply, or an incorrect connection to the equipment.

Service and Repairs

All repairs are made at G.R.A.S. International Support Center located in Denmark. Our Support Center is equipped with the newest test equipment and staffed with dedicated and highly skilled engineers. Upon request, we make cost estimates based on fixed repair categories. If a product covered by warranty is sent for service, it is repaired free of charge, unless the damage is the result of negligent use or other violations of the warranty. All repairs are delivered with a service report, as well as an updated calibration chart.

Manufactured to conform with:

CE marking directive:
93/68/EEC



WEEE directive:
2002/96/EC



RoHS directive:
2002/95/EC



G.R.A.S. Sound & Vibration continually strives to improve the quality of our products for our customers; therefore, the specifications and accessories are subject to change.