

# Low-Frequency Calibrator Type 42AE

## Product Data and Specifications

### Applications

- *Low-frequency pressure response measurements*
- *Low-frequency phase response measurements*
- *Comparative measurements*
- *Single and dual-channel measurements*

### And features

- *All microphone sizes from 1/8", 1/4", 1/2" and 1"*
- *Front and rear-vented microphones*
- *Frequency range<sup>1</sup> from 0.27 Hz–100 Hz*
- *Calibration levels up to 140 dB (re. 20 µPa)*

The G.R.A.S. Low-Frequency Calibrator Type 42AE (Fig. 1) permits microphone calibration at frequencies down to 0.01 Hz for both front and rear-vented microphones. It produces a constant sound pressure level down to very low frequencies.

The two-port configuration allows the actual sound pressure in the coupler to be monitored by a reference microphone simultaneously with the microphone under test.

The built-in DC-coupled power amplifier enables the calibration to be used for swept-sine, broadband and step function investigations.

The calibrator can be used for both rear-vented and side-vented microphones. In the case of rear-vented microphones, the Type 42AE can seal the microphone from the preamplifier to obtain the response of the microphone independent of other leaks.

The calibration of microphones in the frequency range below 50 Hz requires a special apparatus which exposes the complete microphone to the pressure variations of the calibration signal, and not just the microphone diaphragm alone. The air equaliza-

<sup>1</sup> Preamplifier- and microphone-dependent. See Fig. 4



Fig. 1 Low-Frequency Calibrator Type 42AE

tion system of a microphone is important for determining the low-frequency response, together with the amplifier of the electronic system.

Air equalization must be fast enough to compensate for changes in altitude and barometric conditions, and slow enough not to affect the response of the microphone at the lowest frequencies. Most measurement microphones will be adjusted to a lower limiting frequency of 1–3 Hz. But 0.1 Hz is not unusual for infra-sound measurements as well as for airbag testing.

Fig. 2 shows its essential features. Around the body of the Type 42AE, which houses the coupler and all its pre-assembled contents, are input and output sockets as well as a green LED.

The numbered items (accessories included with the Type 42AE) are, more or less, common to all measurements setups. The manual describes a series of configurations and measurement setups and specifies in detail what numbered items are required in each case.

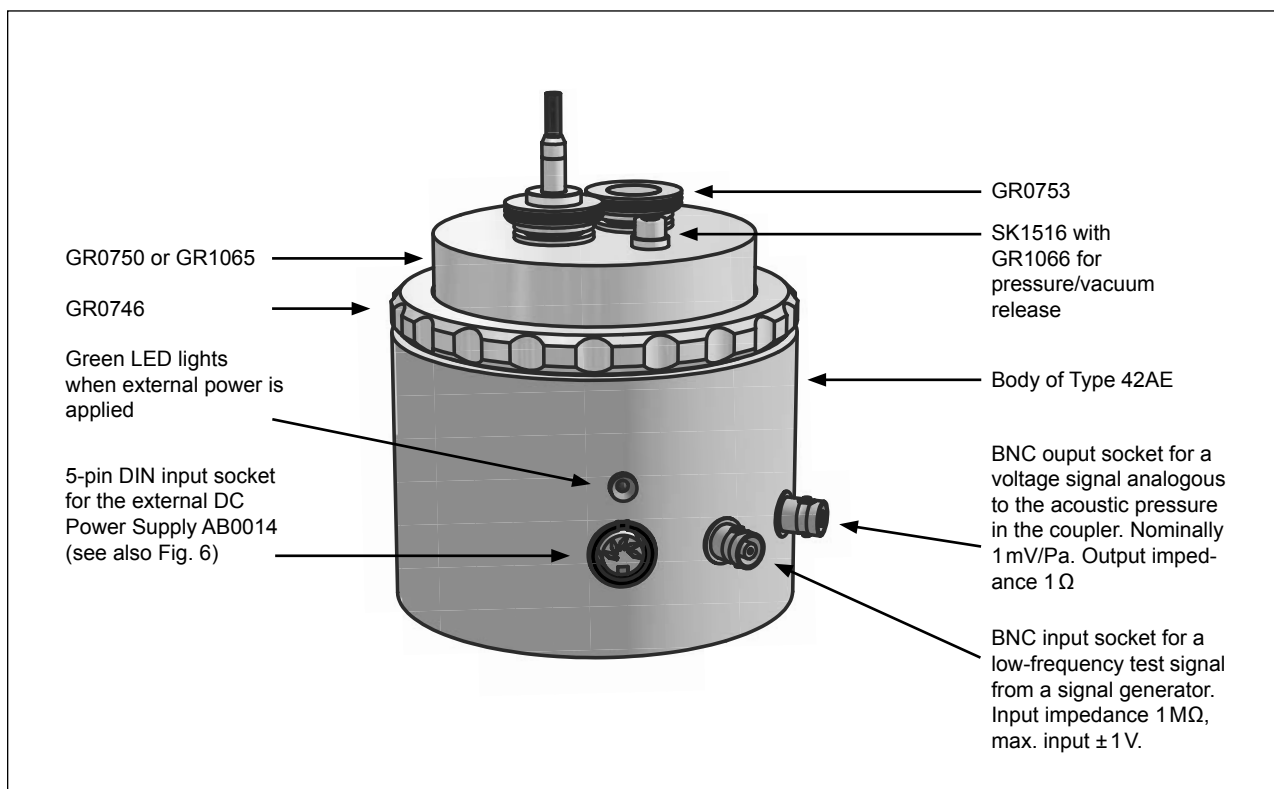

**Fig. 2** External features of the Type 42AE. The numbered items are, more or less, common to all measurements setups

Fig. 3 shows a setup for exploiting the full potential of the Type 42AE.

It can be used for comparing the low-frequency phase and pressure response of a pair of matched microphones (A and B) against each other. Alternatively against the known pressure level and phase angle within the coupler of the Type 42AE.

The voltage signal from the Type 42AE is analogous to the acoustic pressure and phase angle within the coupler of the Type 42AE. The relationship between acoustic pressure and voltage output is nominally 1 mV/Pa (the exact value is given on the calibration chart for each individual Type 42AE).

The dual channel Power Module Type 12AR is recommended because it can be used at frequencies down to 0.05 Hz.

The software in the computer/analyser is capable of generating low-frequency signals as well as processing and presenting all required measurement results in terms of  $SPL/\varnothing_{A \text{ or } B}$  vs.  $SPL/\varnothing_{\text{coup}}$  and/or  $SPL/\varnothing_A$  vs.  $SPL/\varnothing_B$ .

Where A and B refer to the two microphones under test, SPL is the Sound Pressure Level and  $\varnothing$  is the phase angle.

# Low-Frequency Calibrator Type 42AE

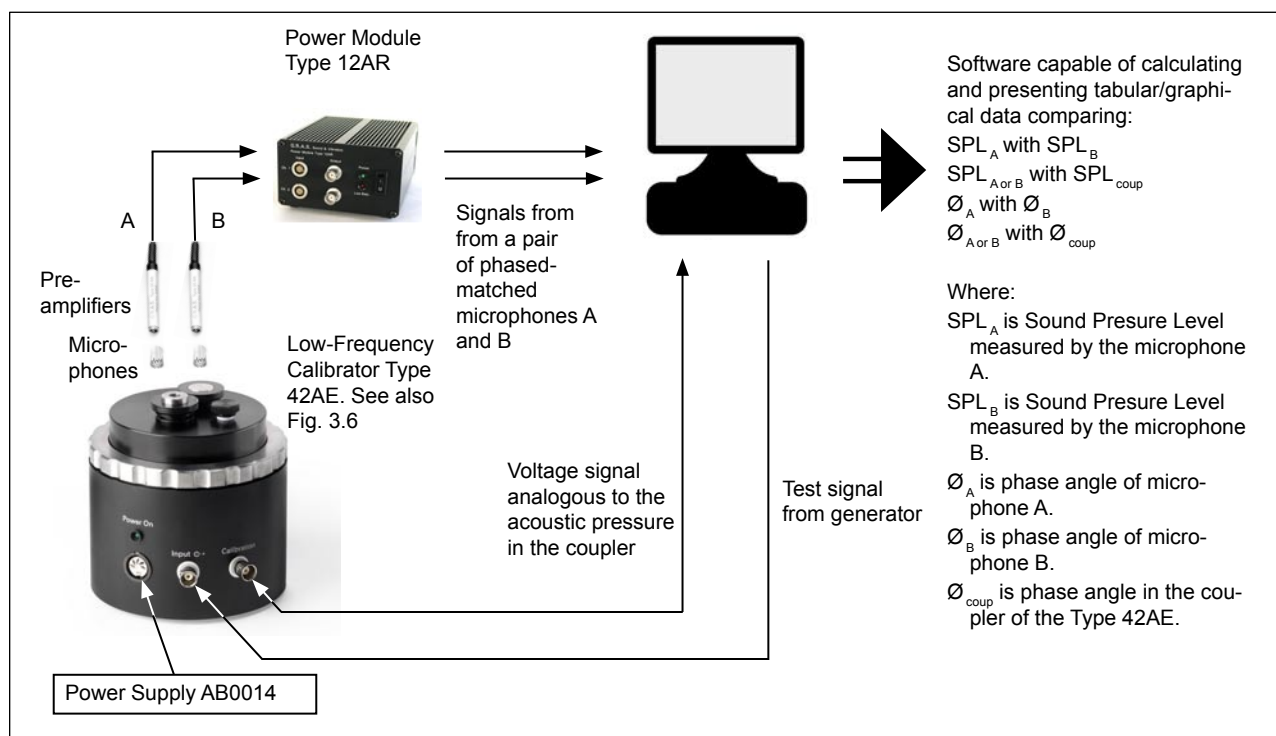

Fig. 3 Setup for comparing the low-frequency phase and pressure response of a pair of matched microphones (A and B) against each other. Alternatively against the known pressure level and phase angle within the coupler of the Type 42AE.

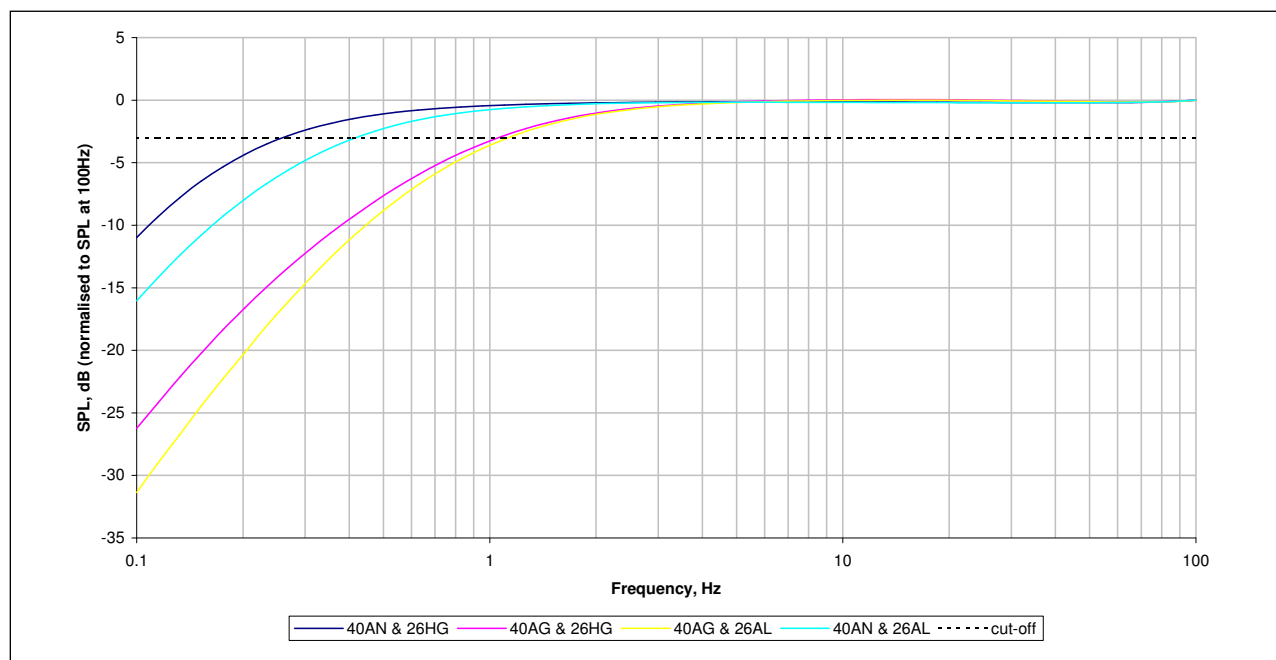

Fig. 4 Usable frequency ranges depending upon various combinations of microphones (Types 40AG and 40AN) and preamplifiers (Types 26AL and 26HG). The dotted line is at  $-3$  dB

# Low-Frequency Calibrator Type 42AE

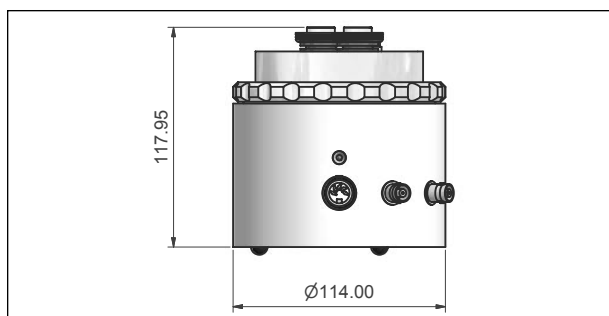

Fig.5 Overall dimensions of the Type 42AE

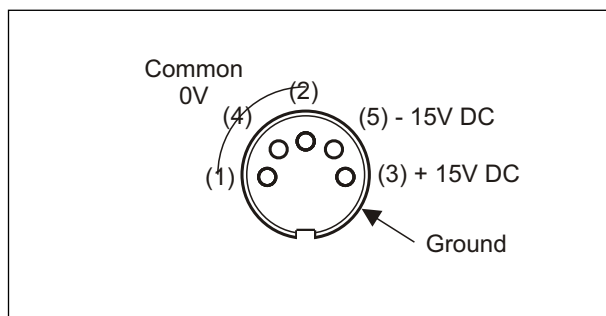

Fig.6 5-pin DIN input socket for the external DC Power Supply AB0014

## Specifications

### Calibration level:

Max. level: ..... 140 dB (re. 20  $\mu$ Pa)

### Usable frequency ranges (preamp. and mic. dependent - see Fig. 4):

#### Ranging:

from: ..... 0.27 Hz (-3 dB) to 100 Hz  
to: ..... 1.1 Hz (-3 dB) to 100 Hz

### Signal input:

Socket: ..... BNC  
Input level: .....  $\pm 1$  V max.  
Impedance: ..... 1 M $\Omega$

### Signal output (analogous to acoustic pressure in coupler):

Socket: ..... BNC  
Output level: ..... 1 mV/Pa  
Impedance: ..... 1  $\Omega$

### Power (provided by included external DC power supply AB0014):

Socket (see Fig. 6): ..... 5-pin DIN  
Voltage supply: .....  $\pm 15$  V  
Current: ..... 1 A max.

### Accessories included:

#### Pre-assembled items:

- Main body
- Mount for 1" microphones
- 2  $\times$  Contacts for RA0063-S1

#### Calibrator Heads:

- For  $\frac{1}{8}$ ",  $\frac{1}{4}$ " and  $\frac{1}{2}$ " mics.: ..... GR0750
- For 1" mic.: ..... GR1065

- Plug: ..... GR1061
- Retaining ring: ..... GR0745
- 2  $\times$  Adapter housings: ..... GR0753
- 2  $\times$  2.2 mm spacers: ..... GR0752
- 2  $\times$  3.7 mm spacers: ..... GR0757
- 2  $\times$  Sleeves for  $\frac{1}{4}$ " preamps.: ..... GR1147
- 2  $\times$  Inserts for  $\frac{1}{4}$ " mics.: ..... GR1138
- 2  $\times$  Inserts for  $\frac{1}{8}$ " mics.: ..... GR1140
- 2  $\times$  Adapters for  $\frac{1}{8}$ " to  $\frac{1}{4}$ " mics.: ..... RA0063-S1
- Gasket washer: ..... GR1066
- Screw: ..... GR1516
- Power supply: ..... AB0014

### Accessories available:

#### Preamplifiers:

- $\frac{1}{4}$ " Preamplifier: ..... Type 26AL
- $\frac{1}{4}$ " Preamplifier: ..... Type 26HG

#### Microphones:

- $\frac{1}{2}$ " Microphone: ..... Type 40AG
- $\frac{1}{2}$ " Microphone: ..... Type 40AN
- 1" Microphone: ..... Type 40EN
- Dual-channel Power module: ..... Type 12AR

### Dimensions (as shown in Fig 5):

- Height: ..... 117.95 mm (4.64")
- Diameter: ..... 114.0 mm (4.49")

### Weight (as shown in Fig 5):

1.58 kg (3 $\frac{1}{2}$  lbs)

G.R.A.S. Sound & Vibration reserves the right to change specifications and accessories without notice